

Content

RO-flex 55 N

Page 5

RO-flex 85 N

Page 23

RO-flex 195 N

Page 49

Accessories

Page 67

Note: The system is also available in the same dimensions in aluminium

Technical description

Page 88

Regulations, Instructions

Page 101

Content RO-flex 55 N

| | |
|-----------------------------|---------|
| Chassis | Page 7 |
| Chain | Page 9 |
| Drive units | Page 12 |
| Idler units | Page 16 |
| Wheel bends | Page 17 |
| Horizontal bends | Page 18 |
| Vertical bends | Page 20 |
| Supports | Page 68 |
| Side guides | Page 73 |
| Accessories, general | Page 86 |

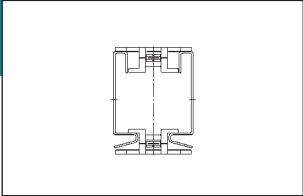

| | Description | Unit | Art. No. |
|--|--|--------|----------|
| | <p>RO-flex 55N</p> <p>Chassis profile 3m 55x67N</p> <p>Stainless steel 1.4301, continuously punched without chain inlet</p> <p>Length = 3.000 mm</p> | 1 pair | 301620 |
| | <p>RO-flex 55N</p> <p>Chassis profile 2m 55x67N</p> <p>Stainless steel 1.4301, continuously punched without chain inlet</p> <p>Length = 2.000 mm</p> | 1 pair | 301621 |
| | <p>RO-flex 55N</p> <p>Chassis profile cutting out 55x67N-K1</p> <p>Stainless steel 1.4301, continuously punched incl. chain inlet one-side</p> <p>By order indicate wished length (max. 3.000 mm).</p> <p>e.g.: length= 2.560 mm= Art. No. 301625-L2560</p> | 1 pair | 301625-L |

Chassis

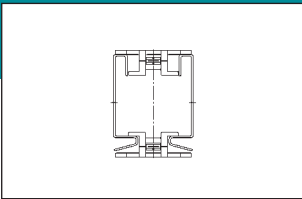

| | Description | Unit | Art. No. |
|--|--|--------|----------|
| | <p>RO-flex 55N</p> <p>Chassis connector 55N-assembly kit</p> <p>Stainless steel 1.4301 incl. fastening elements</p> | 1 pcs. | 301603 |
| | <p>RO-flex 55N</p> <p>Cross connection 55N-assembly kit</p> <p>Stainless steel 1.4301 incl. fastening elements</p> | 1 pcs. | 301602 |

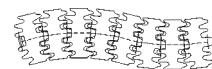

| | Description | Unit | Art. No. |
|--|---|----------|----------|
| | <p>RO-flex 55</p> <p>Chain RT55</p> <p>POM white Length approx. 3 m</p> | 1 pcs. | 301700 |
| | <p>RO-flex 55</p> <p>Chain link RT55</p> <p>POM white Single link, incl. bolt</p> | 1 pcs. | 301701 |
| | <p>RO-flex 55</p> <p>Chain bolt 55-4.5x18</p> <p>Stainless steel 1.4301</p> | 100 pcs. | 301720 |

Chain

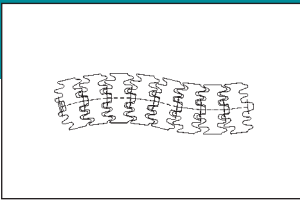

| | Description | Unit | Art. No. |
|--|--|--------|-----------|
| | <p>RO-flex 55</p> <p>Chain with strip RT55-H5.5-MA</p> <p>POM white Length approx. 3 m By order indicate strip distance.</p> <p>Example: every 6th link with strip = Art. No. 301750-MA6</p> | 1 pcs. | 301750-MA |
| | <p>RO-flex 55</p> <p>Chain link with strip RT55-H5.5</p> <p>POM white Single link, incl. bolt</p> | 1 pcs. | 301751 |
| | <p>RO-flex 55</p> <p>Chain with strip RT55-H10-MA</p> <p>POM white Length approx. 3 m By order indicate strip distance.</p> <p>Example: every 6th link with strip = Art. No. 301760-MA6</p> | 1 pcs. | 301760-MA |

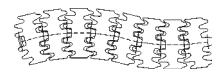

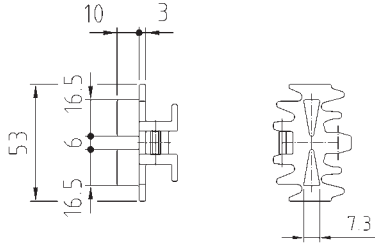
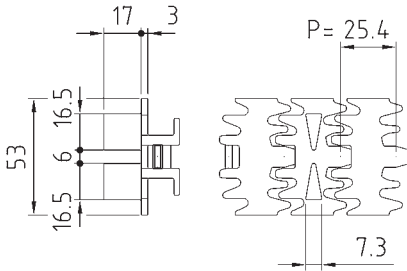
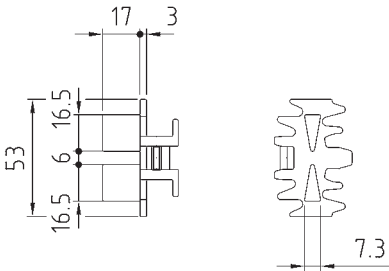
| | Description | Unit | Art. No. |
|---|---|--------|-----------|
|  | <p>RO-flex 55</p> <p>Chain link with strip RT55-H10</p> <p>POM white Single link, incl. bolt</p> | 1 pcs. | 301761 |
|  | <p>RO-flex 55</p> <p>Chain with strip RT55-H17-MA</p> <p>POM white Length approx. 3 m By order indicate strip distance.</p> <p>Example: every 6th link with strip = Art. No. 301770-MA6</p> | 1 pcs. | 301770-MA |
|  | <p>RO-flex 55</p> <p>Chain link with strip RT55-H17</p> <p>POM white Single link, incl. bolt</p> | 1 pcs. | 301771 |

Drive units

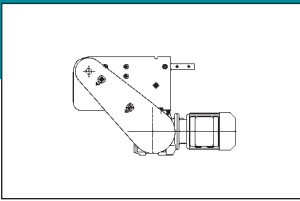

| | Description | Unit | Art. No. |
|--|---|--------|-----------|
| | <p>RO-flex 55N</p> <p>Head drive station KA55N-R with motor</p> <p>Motor on the right</p> <p>In the extent of supply contain: motor, sprockets, rolling chain, chain guard, attachment elements, pre-finished.</p> <p>Necessary chain length: 750 mm</p> | 1 pcs. | 302201 |
| | <p>RO-flex 55N</p> <p>Head drive station KA55N-R without motor</p> <p>Motor on the right</p> <p>In the extent of supply contain: motor plate for gear motor SEW-S37 ..., chain guard, attachment elements.</p> <p>Necessary chain length: 750 mm</p> | 1 pcs. | 302201-oM |
| | <p>RO-flex 55N</p> <p>Head drive station KA55N-L with motor</p> <p>Motor on the left</p> <p>In the extent of supply contain: motor, sprockets, rolling chain, chain guard, attachment elements, pre-finished.</p> <p>Necessary chain length: 750 mm</p> | 1 pcs. | 302202 |

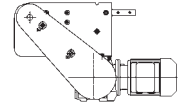

| | Description | Unit | Art. No. |
|--|---|--------|-----------|
| | <p>RO-flex 55N</p> <p>Head drive station KA55N-L without motor</p> <p>Motor on the left</p> <p>In the extent of supply contain: motor plate for gear motor SEW-S37 ..., chain guard, attachment elements.</p> <p>Necessary chain length: 750 mm</p> | 1 pcs. | 302202-oM |
| | <p>RO-flex 55N</p> <p>Middle drive station MA55N-R with motor</p> <p>Motor on the right</p> <p>In the extent of supply contain: motor, sprockets, rolling chain, chain guard, attachment elements, pre-finished.</p> <p>Necessary chain length: 820 mm</p> | 1 pcs. | 302220 |
| | <p>RO-flex 55N</p> <p>Middle drive station MA55N-R without motor</p> <p>Motor on the right</p> <p>In the extent of supply contain: motor plate for gear motor SEW-S37 ..., chain guard, attachment elements.</p> <p>Necessary chain length: 820 mm</p> | 1 pcs. | 302220-oM |

Drive units

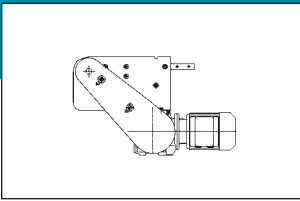

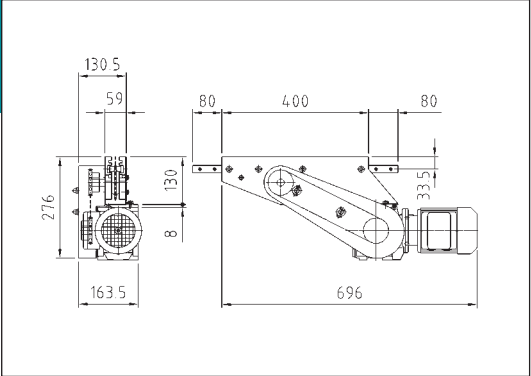
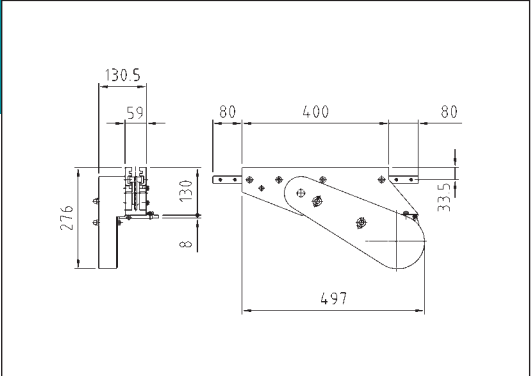
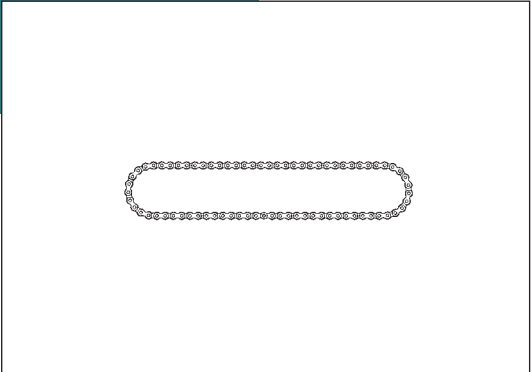
| | Description | Unit | Art. No. |
|---|--|--------|-----------|
|  | <p>RO-flex 55N</p> <p>Middle drive station MA55N-L with motor</p> <p>Motor on the left</p> <p>In the extent of supply contain: motor, sprockets, rolling chain, chain guard, attachment elements, pre-finished.</p> <p>Necessary chain length: 820 mm</p> | 1 pcs. | 302221 |
|  | <p>RO-flex 55N</p> <p>Middle drive station MA55N-L without motor</p> <p>Motor on the left</p> <p>In the extent of supply contain: motor plate for gear motor SEW-S37 ..., chain guard, attachment elements.</p> <p>Necessary chain length: 820 mm</p> | 1 pcs. | 302221-oM |
|  | <p>RO-flex 55N</p> <p>Roller chain 1/2" nickel plated RK-08B-1-64E</p> <p>Endless 812.8 mm incl. coupler link</p> | 1 pcs. | 901901 |

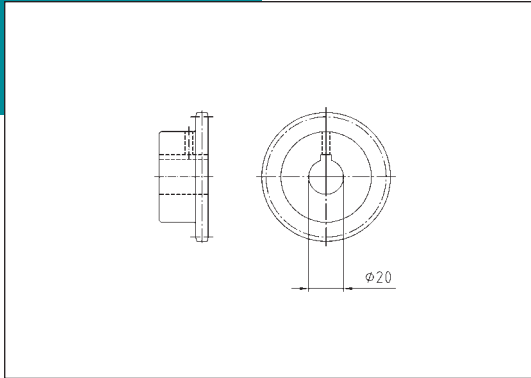
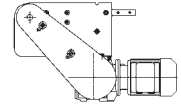

Description

Unit

Art. No.

RO-flex 55N/85N/195N

Chain sprocket 1/2 " -Z15

1 pcs.

102381

Chain sprocket 1/2 " -Z16

1 pcs.

102382

Chain sprocket 1/2 " -Z17

1 pcs.

102383

Chain sprocket 1/2 " -Z18

1 pcs.

102384

Chain sprocket 1/2 " -Z19

1 pcs.

102385

Chain sprocket 1/2 " -Z20

1 pcs.

102386

Chain sprocket 1/2 " -Z21

1 pcs.

102387

Chain sprocket 1/2 " -Z22

1 pcs.

102388

Steel nickel-plate
Drilling 20H7 with wedge lane, incl. thread pencil

fitting to drive shaft (max. Z18)
and gear motor SEW-S37 ...

Idler units

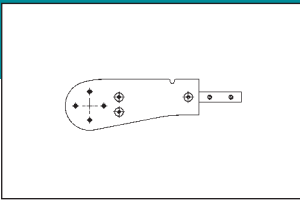

| | Description | Unit | Art. No. |
|--|---|---------------|---------------|
| | <p>RO-flex 55N</p> <p>Idler 180°</p> <p>PE/Stainless steel 1.4301 incl. fastening elements</p> <p>Necessary chain length: 550 mm</p> | <p>1 pcs.</p> | <p>302701</p> |

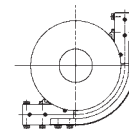

| | Description | Unit | Art. No. |
|--|--|---------------|---------------|
| | <p>RO-flex 55N</p> <p>Wheel bend 90°</p> <p>PC/Stainless steel 1.4301 incl. fastening elements</p> <p>Necessary chain length: 650 mm</p> | <p>1 pcs.</p> | <p>304304</p> |
| | <p>RO-flex 55N</p> <p>Wheel bend 180°</p> <p>PC/Stainless steel 1.4301 incl. fastening elements</p> <p>Necessary chain length: 1.050 mm</p> | <p>1 pcs.</p> | <p>304305</p> |

Horizontal bends

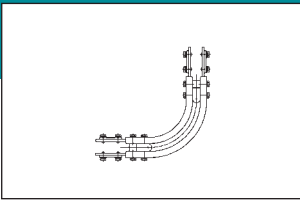

| | Description | Unit | Art. No. |
|---------------|--|--------|----------|
| <p>View A</p> | <p>RO-flex 55N</p> <p>Horizontal bend 15°</p> <p>PE/Stainless steel 1.4301, incl. fastening elements Radius R= 125 mm</p> <p>Necessary chain length: 325 mm</p> | 1 pcs. | 303081 |
| <p>View A</p> | <p>RO-flex 55N</p> <p>Horizontal bend 30°</p> <p>PE/Stainless steel 1.4301, incl. fastening elements Radius R= 125 mm</p> <p>Necessary chain length: 390 mm</p> | 1 pcs. | 303082 |
| <p>View A</p> | <p>RO-flex 55N</p> <p>Horizontal bend 45°</p> <p>PE/Stainless steel 1.4301, incl. fastening elements Radius R= 125 mm</p> <p>Necessary chain length: 460 mm</p> | 1 pcs. | 303083 |

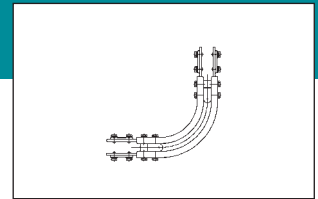

| | Description | Unit | Art. No. |
|--|---|---------------|---------------|
| | <p>RO-flex 55N</p> <p>Horizontal bend 60°</p> <p>PE/Stainless steel 1.4301, incl. fastening elements Radius R= 125 mm</p> <p>Necessary chain length: 525 mm</p> | <p>1 pcs.</p> | <p>303084</p> |
| | <p>RO-flex 55N</p> <p>Horizontal bend 90°</p> <p>PE/Stainless steel 1.4301, incl. fastening elements Radius R= 125 mm</p> <p>Necessary chain length: 650 mm</p> | <p>1 pcs.</p> | <p>303085</p> |
| | <p>RO-flex 55N</p> <p>Connecting strip E 20/6x120</p> <p>Stainless steel 1.4301 For the direct join of bends.</p> <p>Replace the premounted strips by the strips 301607. Reuse disassembled screws.</p> | <p>1 pcs.</p> | <p>301607</p> |

Vertical bends

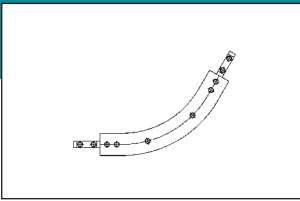

| | Description | Unit | Art. No. |
|--|--|--------|----------|
| | <p>RO-flex 55N</p> <p>Vertical bend 5°</p> <p>PE/Stainless steel 1.4301, incl. fastening elements Radius R= 300 mm</p> <p>Necessary chain length: 315 mm</p> | 1 pcs. | 303551 |
| | <p>RO-flex 55N</p> <p>Vertical bend 10°</p> <p>PE/Stainless steel 1.4301, incl. fastening elements Radius R= 300 mm</p> <p>Necessary chain length: 365 mm</p> | 1 pcs. | 303552 |
| | <p>RO-flex 55N</p> <p>Vertical bend 15°</p> <p>PE/Stainless steel 1.4301, incl. fastening elements Radius R= 300 mm</p> <p>Necessary chain length: 420 mm</p> | 1 pcs. | 303553 |

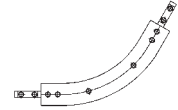

| | Description | Unit | Art. No. |
|--|--|--------|----------|
| | <p>RO-flex 55N</p> <p>Vertical bend 30°</p> <p>PE/Stainless steel 1.4301, incl. fastening elements Radius R= 300 mm</p> <p>Necessary chain length: 575 mm</p> | 1 pcs. | 303554 |
| | <p>RO-flex 55N</p> <p>Vertical bend 45°</p> <p>PE/Stainless steel 1.4301, incl. fastening elements Radius R= 300 mm</p> <p>Necessary chain length: 730 mm</p> | 1 pcs. | 303555 |
| | <p>RO-flex 55N</p> <p>Vertical bend 60°</p> <p>PE/Stainless steel 1.4301, incl. fastening elements Radius R= 300 mm</p> <p>Necessary chain length: 890 mm</p> | 1 pcs. | 303556 |

Vertical bends

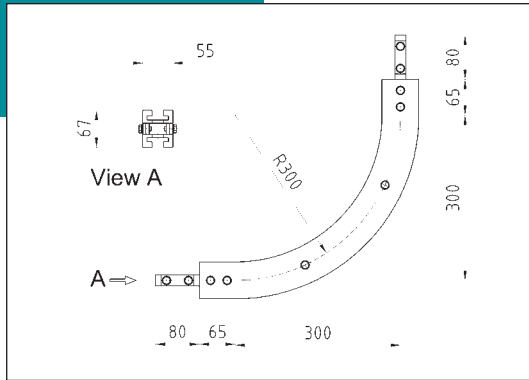
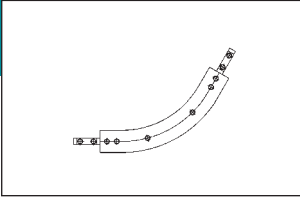

Description

Unit

Art. No.

RO-flex 55N

Vertical bend 90°

1 pcs.

303557

PE/Stainless steel 1.4301, incl. fastening elements
Radius R= 300 mm

Necessary guide rail: 1.200 mm

Content RO-flex 85 N

| | | |
|-----------------------------|------|----|
| Chassis | Page | 25 |
| Chain | Page | 28 |
| Drive units | Page | 33 |
| Idler units | Page | 37 |
| Wheel bends | Page | 38 |
| Horizontal bends | Page | 40 |
| Vertical bends | Page | 45 |
| Supports | Page | 68 |
| Side guides | Page | 73 |
| Accessories, general | Page | 86 |

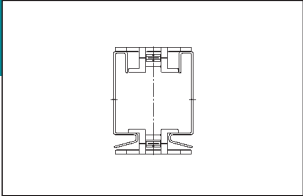

| | Description | Unit | Art. No. |
|--|--|--------|----------|
| | <p>RO-flex 85N</p> <p>Chassis profile 3m 85x77N</p> <p>Stainless steel 1.4301, continuously punched without chain inlet</p> <p>Length = 3.000 mm</p> | 1 pair | 101620 |
| | <p>RO-flex 85N</p> <p>Chassis profile 2m 85x77N</p> <p>Stainless steel 1.4301, continuously punched without chain inlet</p> <p>Length = 2.000 mm</p> | 1 pair | 101621 |
| | <p>RO-flex 85N</p> <p>Chassis profile cutting out 85x77N-K1</p> <p>Stainless steel 1.4301, continuously punched incl. chain inlet one-side</p> <p>By order indicate wished length (max. 3.000 mm).</p> <p>e.g.: length= 2.560 mm= Art. No. 101625-L2650</p> | 1 pair | 101625-L |

Chassis

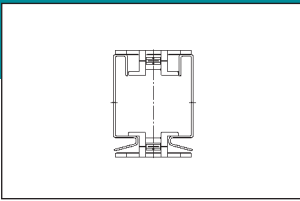

| | Description | Unit | Art. No. |
|--|--|--------|----------|
| | <p>RO-flex 85N</p> <p>Chassis connector 85N-assembly kit</p> <p>Stainless steel 1.4301 incl. fastening elements</p> | 1 pcs. | 101603 |
| | <p>RO-flex 85N</p> <p>Cross connection 85N-assembly kit</p> <p>Stainless steel 1.4301 incl. fastening elements</p> | 1 pcs. | 101602 |
| | <p>RO-flex 85N</p> <p>Connector strip type C 85N-assembly kit</p> <p>Stainless steel 1.4301 incl. fastening elements</p> <p>For connecting wheel bend at chassis and idler 180° at chassis.</p> | 1 pcs. | 101605 |

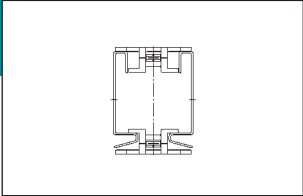

| | Description | Unit | Art. No. |
|--|---|---------------|---------------|
| | <p>RO-flex 85N</p> <p>Drill pattern for chassis</p> <p>Aluminium</p> | <p>1 pcs.</p> | <p>101630</p> |

Chain

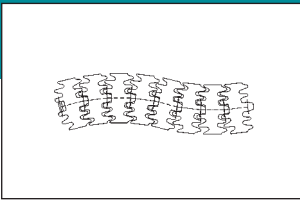

| | Description | Unit | Art. No. |
|--|--|----------|----------|
| | <p>RO-flex 85</p> <p>Chain PLS85</p> <p>POM white Length approx. 3 m</p> | 1 pcs. | 101710 |
| | <p>RO-flex 85</p> <p>Chain link PLS85</p> <p>POM white Single link, incl. bolt</p> | 1 pcs. | 101711 |
| | <p>RO-flex 85</p> <p>Chain bolt 85-6.7x38.5</p> <p>Stainless steel 1.4301</p> | 100 pcs. | 101720 |

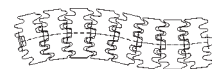

| | Description | Unit | Art. No. |
|--|---|--------|-----------|
| | <p>RO-flex 85</p> <p>Chain with strip PLS85-H5.5-MA</p> <p>POM white Length approx. 3 m By order indicate strip distance.</p> <p>Example: every 6th link with strip = Art. No. 101760-MA6</p> | 1 pcs. | 101760-MA |
| | <p>RO-flex 85</p> <p>Chain link with strip PLS85-H5.5</p> <p>POM white Single link, incl. bolt</p> | 1 pcs. | 101761 |
| | <p>RO-flex 85</p> <p>Chain with strip PLS85-H10-MA</p> <p>POM white Length approx. 3 m By order indicate strip distance.</p> <p>Example: every 6th link with strip = Art. No. 101770-MA6</p> | 1 pcs. | 101770-MA |

Chain

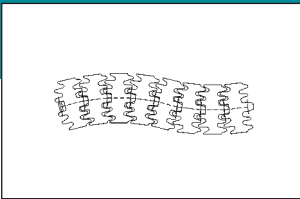

| | Description | Unit | Art. No. |
|--|--|--------|-----------|
| | <p>RO-flex 85</p> <p>Chain link with strip PLS85-H10</p> <p>POM white Single link, incl. bolt</p> | 1 pcs. | 101771 |
| | <p>RO-flex 85</p> <p>Chain with strip PLS85-H17-MA</p> <p>POM white Length approx. 3 m By order indicate strip distance.</p> <p>Example: every 6th link with strip = Art. No. 101780-MA6</p> | 1 pcs. | 101780-MA |
| | <p>RO-flex 85</p> <p>Chain link with strip PLS85-H17</p> <p>POM white Single link, incl. bolt</p> | 1 pcs. | 101781 |

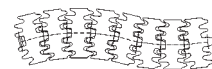

| | Description | Unit | Art. No. |
|--|--|--------|-----------|
| | <p>RO-flex 85</p> <p>Chain with strip PLS85-H40-MA</p> <p>POM white Length approx. 3 m By order indicate strip distance.</p> <p>Example: every 6th link with strip = Art. No. 101813-MA6</p> | 1 pcs. | 101813-MA |
| | <p>RO-flex 85</p> <p>Chain link with strip PLS85-H40</p> <p>POM white Single link, incl. bolt</p> | 1 pcs. | 101814 |
| | <p>RO-flex 85</p> <p>Chain with adhesiv coating PLS85-white-MA</p> <p>POM white Length approx. 3 m By order indicate strip distance.</p> <p>Example: every 6th link with strip = Art. No. 101825-MA6</p> | 1 pcs. | 101825-MA |

Chain

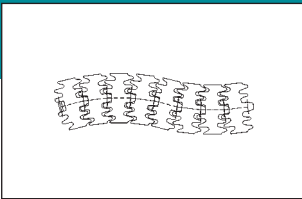

| | Description | Unit | Art. No. |
|--|---|--------|-----------|
| | <p>RO-flex 85</p> <p>Chain link with adhesiv coating PLS85-white</p> <p>POM white Single link, incl. bolt</p> | 1 pcs. | 101826 |
| | <p>RO-flex 85</p> <p>Chain with adhesiv coating RT85-green-MA</p> <p>POM white Length approx. 3 m By order indicate strip distance.</p> <p>Example: every 6th link with strip = Art. No. 101835-MA6</p> | 1 pcs. | 101835-MA |
| | <p>RO-flex 85</p> <p>Chain link with adhesiv coating RT85-green</p> <p>POM white Single link, incl. bolt</p> | 1 pcs. | 101836 |

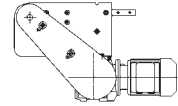

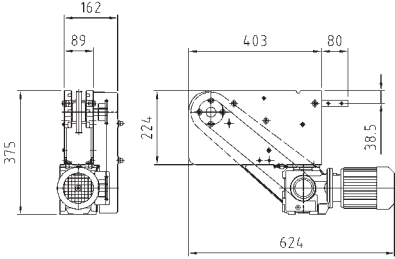
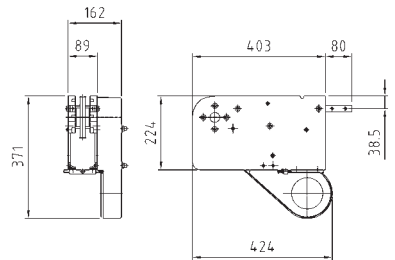
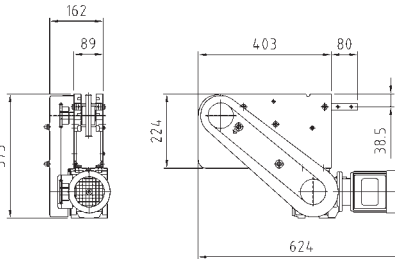
| | Description | Unit | Art. No. |
|---|---|--------|-----------|
|  | <p>RO-flex 85N</p> <p>Head drive station KA85N-R with motor</p> <p>Motor on the right</p> <p>In the extent of supply contain: motor, sprockets, rolling chain, chain guard, attachment elements, pre-finished.</p> <p>Necessary chain length: 950 mm</p> | 1 pcs. | 102201 |
|  | <p>RO-flex 85N</p> <p>Head drive station KA85N-R without motor</p> <p>Motor on the right</p> <p>In the extent of supply contain: motor plate for gear motor SEW-S37 ..., chain guard, attachment elements.</p> <p>Necessary chain length: 950 mm</p> | 1 pcs. | 102201-oM |
|  | <p>RO-flex 85N</p> <p>Head drive station KA85N-L with motor</p> <p>Motor on the left</p> <p>In the extent of supply contain: motor, sprockets, rolling chain, chain guard, attachment elements, pre-finished.</p> <p>Necessary chain length: 950 mm</p> | 1 pcs. | 102202 |

Drive units

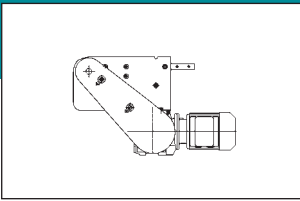

| | Description | Unit | Art. No. |
|--|--|--------|-----------|
| | <p>RO-flex 85N</p> <p>Head drive station KA85N-L without motor</p> <p>Motor on the left</p> <p>In the extent of supply contain: motor plate for gear motor SEW-S37 ..., chain guard, attachment elements.</p> <p>Necessary chain length: 950 mm</p> | 1 pcs. | 102202-oM |
| | <p>RO-flex 85N</p> <p>Middle drive station MA85N-R with motor</p> <p>Motor on the right</p> <p>In the extent of supply contain: motor, sprockets, rolling chain, chain guard, attachment elements, pre-finished.</p> <p>Necessary chain length: 940 mm</p> | 1 pcs. | 102440 |
| | <p>RO-flex 85N</p> <p>Middle drive station MA85N-R without motor</p> <p>Motor on the right</p> <p>In the extent of supply contain: motor plate for gear motor SEW-S37 ..., chain guard, attachment elements.</p> <p>Necessary chain length: 940 mm</p> | 1 pcs. | 102440-oM |

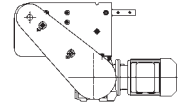

| | Description | Unit | Art. No. |
|--|--|--------|-----------|
| | <p>RO-flex 85N</p> <p>Middle drive station MA85N-L with motor</p> <p>Motor on the left</p> <p>In the extent of supply contain: motor, sprockets, rolling chain, chain guard, attachment elements, pre-finished.</p> <p>Necessary chain length: 940 mm</p> | 1 pcs. | 102441 |
| | <p>RO-flex 85N</p> <p>Middle drive station MA85N-L without motor</p> <p>Motor on the left</p> <p>In the extent of supply contain: motor plate for gear motor SEW-S37 ..., chain guard, attachment elements.</p> <p>Necessary chain length: 940 mm</p> | 1 pcs. | 102441-oM |
| | <p>RO-flex 85N/195N</p> <p>Roller chain 1/2" nickel plated RK-08B-1-78E</p> <p>Endless 965.2 mm incl. coupler link</p> | 1 pcs. | 901900 |

Drive units

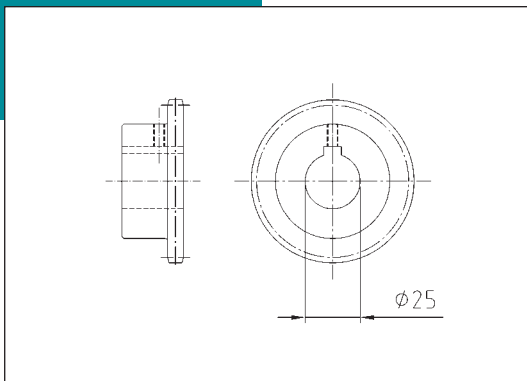
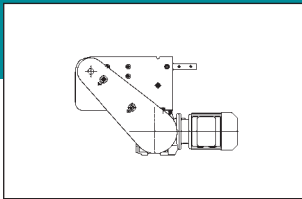

Description

Unit

Art. No.

RO-flex 85N/195N

| | | |
|----------------------------------|--------|--------|
| Chain sprocket 1/2 " -Z15 | 1 pcs. | 102351 |
| Chain sprocket 1/2 " -Z16 | 1 pcs. | 102352 |
| Chain sprocket 1/2 " -Z17 | 1 pcs. | 102353 |
| Chain sprocket 1/2 " -Z18 | 1 pcs. | 102354 |
| Chain sprocket 1/2 " -Z19 | 1 pcs. | 102355 |
| Chain sprocket 1/2 " -Z20 | 1 pcs. | 102356 |
| Chain sprocket 1/2 " -Z21 | 1 pcs. | 102357 |
| Chain sprocket 1/2 " -Z22 | 1 pcs. | 102358 |

Steel nickel-plate
Drilling 25H7 with wedge lane, incl. thread pencil

fitting to drive shaft
for head and middle drive station

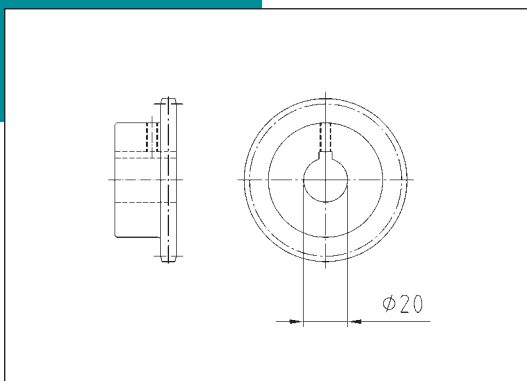

RO-flex 55N/85N/195N

| | | |
|----------------------------------|--------|--------|
| Chain sprocket 1/2 " -Z15 | 1 pcs. | 102381 |
| Chain sprocket 1/2 " -Z16 | 1 pcs. | 102382 |
| Chain sprocket 1/2 " -Z17 | 1 pcs. | 102383 |
| Chain sprocket 1/2 " -Z18 | 1 pcs. | 102384 |
| Chain sprocket 1/2 " -Z19 | 1 pcs. | 102385 |
| Chain sprocket 1/2 " -Z20 | 1 pcs. | 102386 |
| Chain sprocket 1/2 " -Z21 | 1 pcs. | 102387 |
| Chain sprocket 1/2 " -Z22 | 1 pcs. | 102388 |

Steel nickel-plate
Drilling 20H7 with wedge lane, incl. thread pencil

fitting to gear motor S37 ...
for head and middle drive station

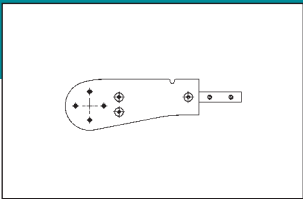

| | Description | Unit | Art. No. |
|--|--|--------|----------|
| | <p>RO-flex 85N</p> <p>Idler 180°</p> <p>PE/Stainless steel 1.4301 incl. fastening elements</p> <p>Necessary chain length: 700 mm</p> | 1 pcs. | 102701 |
| | <p>RO-flex 85N</p> <p>Idler 180° with longer shaft, at right</p> <p>PE/Stainless steel 1.4301 incl. fastening elements</p> <p>Can be used for drive or idler.</p> <p>Necessary chain length: 700 mm</p> | 1 pcs. | 102660 |
| | <p>RO-flex 85N</p> <p>Idler 180° with longer shaft, at left</p> <p>PE/Stainless steel 1.4301 incl. fastening elements</p> <p>Can be used for drive or idler.</p> <p>Necessary chain length: 700 mm</p> | 1 pcs. | 102661 |

Wheel bends

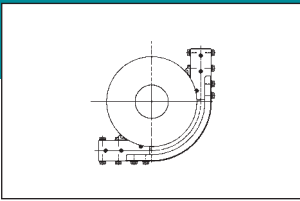

| | Description | Unit | Art. No. |
|--|---|--------|----------|
| | <p>RO-flex 85N</p> <p>Wheel bend 30°</p> <p>PC/Stainless steel 1.4301 incl. fastening elements</p> <p>Necessary chain length: 570 mm</p> | 1 pcs. | 104301 |
| | <p>RO-flex 85N</p> <p>Wheel bend 45°</p> <p>PC/Stainless steel 1.4301 incl. fastening elements</p> <p>Necessary chain length: 675 mm</p> | 1 pcs. | 104302 |
| | <p>RO-flex 85N</p> <p>Wheel bend 60°</p> <p>PC/Stainless steel 1.4301 incl. fastening elements</p> <p>Necessary chain length: 780 mm</p> | 1 pcs. | 104303 |

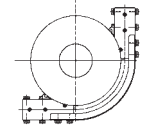

| | Description | Unit | Art. No. |
|--|--|---------------|---------------|
| | <p>RO-flex 85N</p> <p>Wheel bend 90°</p> <p>PC/Stainless steel 1.4301 incl. fastening elements</p> <p>Necessary chain length: 990 mm</p> | <p>1 pcs.</p> | <p>104304</p> |
| | <p>RO-flex 85N</p> <p>Wheel bend 180°</p> <p>PC/Stainless steel 1.4301 incl. fastening elements</p> <p>Necessary chain length: 1.615 mm</p> | <p>1 pcs.</p> | <p>104305</p> |

Horizontal bends

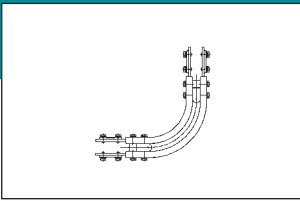

| | Description | Unit | Art. No. |
|---------------|--|--------|----------|
| <p>View A</p> | <p>RO-flex 85N</p> <p>Horizontal bend 15°</p> <p>PE/Stainless steel 1.4301, incl. fastening elements Radius R= 200 mm</p> <p>Necessary chain length: 470 mm</p> | 1 pcs. | 103081 |
| <p>View A</p> | <p>RO-flex 85N</p> <p>Horizontal bend 30°</p> <p>PE/Stainless steel 1.4301, incl. fastening elements Radius R= 200 mm</p> <p>Necessary chain length: 570 mm</p> | 1 pcs. | 103082 |
| <p>View A</p> | <p>RO-flex 85N</p> <p>Horizontal bend 45°</p> <p>PE/Stainless steel 1.4301, incl. fastening elements Radius R= 200 mm</p> <p>Necessary chain length: 675 mm</p> | 1 pcs. | 103083 |

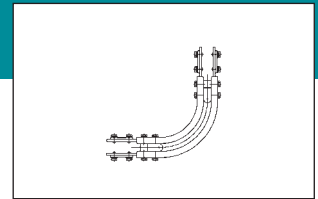

| | Description | Unit | Art. No. |
|--|---|---------------|---------------|
| | <p>RO-flex 85N</p> <p>Horizontal bend 60°</p> <p>PE/Stainless steel 1.4301, incl. fastening elements Radius R= 200 mm</p> <p>Necessary chain length: 780 mm</p> | <p>1 pcs.</p> | <p>103084</p> |
| | <p>RO-flex 85N</p> <p>Horizontal bend 90°</p> <p>PE/Stainless steel 1.4301, incl. fastening elements Radius R= 200 mm</p> <p>Necessary chain length: 990 mm</p> | <p>1 pcs.</p> | <p>103085</p> |
| | <p>RO-flex 85N</p> <p>Horizontal bend 180°</p> <p>PE/Stainless steel 1.4301, incl. fastening elements Radius R= 200 mm</p> <p>Necessary chain length: 1.615 mm</p> | <p>1 pcs.</p> | <p>103086</p> |

Horizontal bends

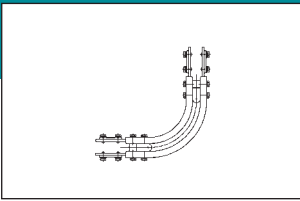

| | Description | Unit | Art. No. |
|--|--|--------|----------|
| | <p>RO-flex 85N</p> <p>Horizontal bend 15°</p> <p>PE/Stainless steel 1.4301, incl. fastening elements Radius R= 500 mm</p> <p>Necessary chain length: 620 mm</p> | 1 pcs. | 103101 |
| | <p>RO-flex 85N</p> <p>Horizontal bend 30°</p> <p>PE/Stainless steel 1.4301, incl. fastening elements Radius R= 500 mm</p> <p>Necessary chain length: 885 mm</p> | 1 pcs. | 103102 |
| | <p>RO-flex 85N</p> <p>Horizontal bend 45°</p> <p>PE/Stainless steel 1.4301, incl. fastening elements Radius R= 500 mm</p> <p>Necessary chain length: 1.145 mm</p> | 1 pcs. | 103103 |

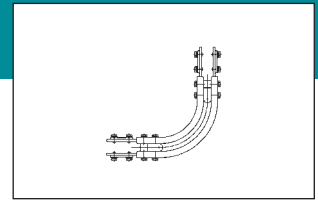

| | Description | Unit | Art. No. |
|--|---|--------|----------|
| | <p>RO-flex 85N</p> <p>Horizontal bend 60°</p> <p>PE/Stainless steel 1.4301, incl. fastening elements Radius R= 500 mm</p> <p>Necessary chain length: 1.410 mm</p> | 1 pcs. | 103104 |
| | <p>RO-flex 85N</p> <p>Horizontal bend 90°</p> <p>PE/Stainless steel 1.4301, incl. fastening elements Radius R= 500 mm</p> <p>Necessary chain length: 1.930 mm</p> | 1 pcs. | 103105 |
| | <p>RO-flex 85N</p> <p>Horizontal bend 180°</p> <p>PE/Stainless steel 1.4301, incl. fastening elements Radius R= 500 mm</p> <p>Necessary chain length: 3.500 mm</p> | 1 pcs. | 103106 |

Horizontal bends

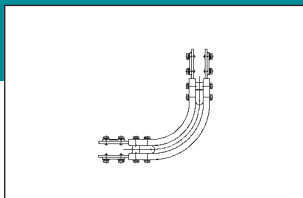

| | Description | Unit | Art. No. |
|--|--|--------|----------|
| | <p>RO-flex 85/195</p> <p>Connecting strip E 20/5x140</p> <p>Stainless steel 1.4301 For the direct join of bends.</p> <p>Replace the premounted strips by the strips 101607. Reuse disassembled screws.</p> | 1 pcs. | 101607 |

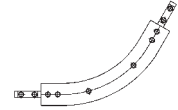

| | Description | Unit | Art. No. |
|--|--|---------------|---------------|
| | <p>RO-flex 85N</p> <p>Vertical bend 5°</p> <p>PE/Stainless steel 1.4301, incl. fastening elements Radius R= 400 mm</p> <p>Necessary chain length: 430 mm</p> | <p>1 pcs.</p> | <p>103551</p> |
| | <p>RO-flex 85N</p> <p>Vertical bend 10°</p> <p>PE/Stainless steel 1.4301, incl. fastening elements Radius R= 400 mm</p> <p>Necessary chain length: 500 mm</p> | <p>1 pcs.</p> | <p>103552</p> |
| | <p>RO-flex 85N</p> <p>Vertical bend 15°</p> <p>PE/Stainless steel 1.4301, incl. fastening elements Radius R= 400 mm</p> <p>Necessary chain length: 570 mm</p> | <p>1 pcs.</p> | <p>103553</p> |

Vertical bends

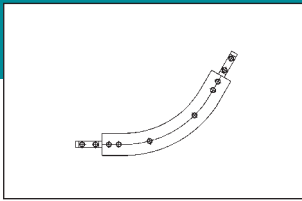

| | Description | Unit | Art. No. |
|--|--|--------|----------|
| | <p>RO-flex 85N</p> <p>Vertical bend 30°</p> <p>PE/Stainless steel 1.4301, incl. fastening elements Radius R= 400 mm</p> <p>Necessary chain length: 780 mm</p> | 1 pcs. | 103554 |
| | <p>RO-flex 85N</p> <p>Vertical bend 45°</p> <p>PE/Stainless steel 1.4301, incl. fastening elements Radius R= 400 mm</p> <p>Necessary chain length: 990 mm</p> | 1 pcs. | 103555 |
| | <p>RO-flex 85N</p> <p>Vertical bend 60°</p> <p>PE/Stainless steel 1.4301, incl. fastening elements Radius R= 400 mm</p> <p>Necessary guide rail: 1.200 mm</p> | 1 pcs. | 103556 |

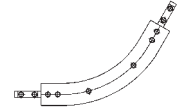

| | Description | Unit | Art. No. |
|--|---|--------|----------|
| | <p>RO-flex 85N</p> <p>Vertical bend 90°</p> <p>PE/Stainless steel 1.4301, incl. fastening elements Radius R= 400 mm</p> <p>Necessary chain length: 1.620 mm</p> | 1 pcs. | 103557 |
| | <p>RO-flex 85N</p> <p>Connector strip type D 85N-assembly kit</p> <p>Stainless steel 1.4301 incl. fastening elements</p> <p>For connecting wheel bend at chassis and Idler 180° at chassis.</p> | 1 pcs. | 101606 |
| | <p>RO-flex 85/195</p> <p>Connecting strip E 20/5x140</p> <p>Stainless steel 1.4301 For the direct join of bends.</p> <p>Replace the premounted strips by the strips 101607. Reuse disassembled screws.</p> | 1 pcs. | 101607 |

Content RO-flex 195 N

| | |
|-----------------------------|---------|
| Chassis | Page 51 |
| Chain | Page 54 |
| Drive units | Page 57 |
| Idler units | Page 60 |
| Horizontal bends | Page 61 |
| Vertical bends | Page 63 |
| Supports | Page 68 |
| Side guides | Page 73 |
| Accessories, general | Page 86 |

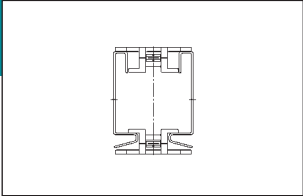

| | Description | Unit | Art. No. |
|--|--|--------|----------|
| | <p>RO-flex 195N</p> <p>Chassis profile outside 2m A-195x80N</p> <p>Stainless steel 1.4301, continuously punched without chain inlet</p> <p>Length = 2.000 mm</p> | 1 pair | 201550 |
| | <p>RO-flex 195N</p> <p>Chassis profile outside 3m A-195x80N</p> <p>Stainless steel 1.4301, continuously punched without chain inlet</p> <p>Length = 3.000 mm</p> | 1 pair | 201551 |
| | <p>RO-flex 195N</p> <p>Chassis profile inside 2m I-195x80N</p> <p>Stainless steel 1.4301, continuously punched without chain inlet</p> <p>Length = 2.000 mm</p> | 1 pair | 201560 |

Chassis

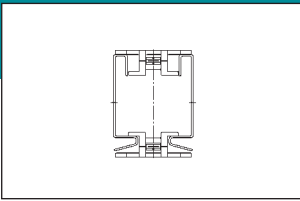

| | Description | Unit | Art. No. |
|--|--|--------|----------|
| | <p>RO-flex 195N</p> <p>Chassis profile inside 3m I-195x80N</p> <p>Stainless steel 1.4301, continuously punched without chain inlet</p> <p>Length = 3.000 mm</p> | 1 pair | 201561 |
| | <p>RO-flex 195N</p> <p>Chassis profile outside cutting out A-195x80N-K1</p> <p>Stainless steel 1.4301, continuously punched incl. chain inlet one-side</p> <p>By order indicate wished length (max. 3.000 mm). e.g.: length= 2.560 mm= Art. No. 201570-L2650</p> | 1 pair | 201570-L |
| | <p>RO-flex 195N</p> <p>Chassis profile inside cutting out I-195x80N-K1</p> <p>Stainless steel 1.4301, continuously punched incl. chain inlet one-side</p> <p>By order indicate wished length (max. 3.000 mm). e.g.: length= 2.560 mm= Art. No. 201571-L2650</p> | 1 pair | 201571-L |

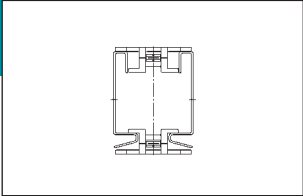

| | Description | Unit | Art. No. |
|--|--|--------|----------|
| | <p>RO-flex 195N</p> <p>Chassis spacer 195N-assembly kit</p> <p>Stainless steel 1.4301 incl. fastening elements</p> | 1 pcs. | 201580 |
| | <p>RO-flex 195N</p> <p>Chassis connector 195N-assembly kit</p> <p>Stainless steel 1.4301 incl. fastening elements</p> | 1 pcs. | 201590 |
| | <p>RO-flex 195N</p> <p>Drill pattern for chassis</p> <p>Aluminium</p> | 1 pcs. | 201600 |

Chain

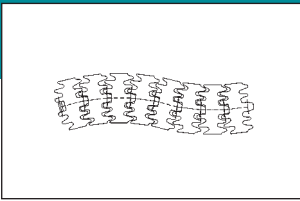

| | Description | Unit | Art. No. |
|--|---|----------|----------|
| | <p>RO-flex 195</p> <p>Chain RT195/4</p> <p>POM white Length approx. 5 m</p> | 1 pcs. | 201850 |
| | <p>RO-flex 195</p> <p>Chain link RT195/4</p> <p>POM white Single link, incl. bolt</p> | 1 pcs. | 201851 |
| | <p>RO-flex 195</p> <p>Chain bolt 195/4-8x54</p> <p>Stainless steel 1.4301</p> | 100 pcs. | 201845 |

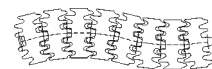

| | Description | Unit | Art. No. |
|--|---|--------|-----------|
| | <p>RO-flex 195</p> <p>Chain with strip RT195/4-H40-MA</p> <p>POM white Length approx. 5 m By order indicate strip distance.</p> <p>Example: every 6th link with strip = Art. No. 201870-MA6</p> | 1 pcs. | 201870-MA |
| | <p>RO-flex 195</p> <p>Chain link with strip RT195/4-H40</p> <p>POM white Single link, incl. bolt</p> | 1 pcs. | 201871 |
| | <p>RO-flex 195</p> <p>Chain with adhesiv coating RT195/4-white-MA</p> <p>POM white Length approx. 5 m By order indicate strip distance.</p> <p>Example: every 6th link with strip = Art. No. 201855-MA6</p> | 1 pcs. | 201855-MA |

Chain

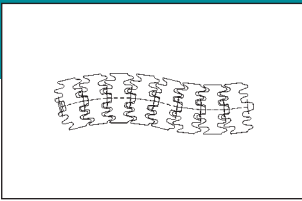

| | Description | Unit | Art. No. |
|--|---|--------|-----------|
| | <p>RO-flex 195</p> <p>Chain link with adhesiv coating RT195/4-white</p> <p>POM white Single link, incl. bolt</p> | 1 pcs. | 201856 |
| | <p>RO-flex 195</p> <p>Chain with adhesiv coating RT195/4-green-MA</p> <p>POM white Length approx. 5 m By order indicate strip distance.</p> <p>Example: every 6th link with strip = Art. No. 201860-MA6</p> | 1 pcs. | 201860-MA |
| | <p>RO-flex 195</p> <p>Chain link with adhesiv coating RT195/4-green</p> <p>POM white Single link, incl. bolt</p> | 1 pcs. | 201861 |

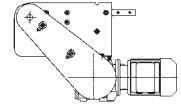

| | Description | Unit | Art. No. |
|--|---|---------------|------------------|
| | <p>RO-flex 195N</p> <p>Head drive station KA195N-R with motor</p> <p>Motor on the right</p> <p>In the extent of supply contain: motor, sprockets, rolling chain, chain guard, attachment elements, pre-finished.</p> <p>Necessary chain length: 950 mm</p> | <p>1 pcs.</p> | <p>202201</p> |
| | <p>RO-flex 195N</p> <p>Head drive station KA195N-R without motor</p> <p>Motor on the right</p> <p>In the extent of supply contain: motor plate for gear motor SEW-S37 ..., chain guard, attachment elements.</p> <p>Necessary chain length: 950 mm</p> | <p>1 pcs.</p> | <p>202201-oM</p> |
| | <p>RO-flex 195N</p> <p>Head drive station KA195N-L with motor</p> <p>Motor on the left</p> <p>In the extent of supply contain: motor, sprockets, rolling chain, chain guard, attachment elements, pre-finished.</p> <p>Necessary chain length: 950 mm</p> | <p>1 pcs.</p> | <p>202202</p> |

Drive units

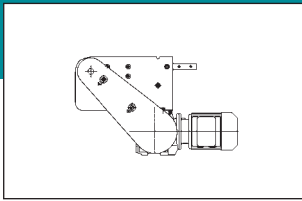

| | Description | Unit | Art. No. |
|--|---|--------|-----------|
| | <p>RO-flex 195N</p> <p>Head drive station KA195N-L without motor</p> <p>Motor on the left</p> <p>In the extent of supply contain: motor plate for gear motor SEW-S37 ..., chain guard, attachment elements.</p> <p>Necessary chain length: 950 mm</p> | 1 pcs. | 202202-oM |
| | <p>RO-flex 85N/195N</p> <p>Roller chain 1/2" nickel plated RK-08B-1-78E</p> <p>Endless 965.2 mm incl. coupler link</p> | 1 pcs. | 901900 |

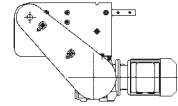

| | Description | Unit | Art. No. |
|--|----------------------------------|--------|----------|
| | RO-flex 85N/195N | | |
| | Chain sprocket 1/2 " -Z15 | 1 pcs. | 102351 |
| | Chain sprocket 1/2 " -Z16 | 1 pcs. | 102352 |
| | Chain sprocket 1/2 " -Z17 | 1 pcs. | 102353 |
| | Chain sprocket 1/2 " -Z18 | 1 pcs. | 102354 |
| | Chain sprocket 1/2 " -Z19 | 1 pcs. | 102355 |
| | Chain sprocket 1/2 " -Z20 | 1 pcs. | 102356 |
| | Chain sprocket 1/2 " -Z21 | 1 pcs. | 102357 |
| Chain sprocket 1/2 " -Z22 | 1 pcs. | 102358 | |
| Steel nickel-plate Drilling 25H7 with wedge lane, incl. thread pencil fitting to drive shaft at head drive station | | | |
| | RO-flex 55N/85N/195N | | |
| | Chain sprocket 1/2 " -Z15 | 1 pcs. | 102381 |
| | Chain sprocket 1/2 " -Z16 | 1 pcs. | 102382 |
| | Chain sprocket 1/2 " -Z17 | 1 pcs. | 102383 |
| | Chain sprocket 1/2 " -Z18 | 1 pcs. | 102384 |
| | Chain sprocket 1/2 " -Z19 | 1 pcs. | 102385 |
| | Chain sprocket 1/2 " -Z20 | 1 pcs. | 102386 |
| | Chain sprocket 1/2 " -Z21 | 1 pcs. | 102387 |
| Chain sprocket 1/2 " -Z22 | 1 pcs. | 102388 | |
| Steel nickel-plate Drilling 20H7 with wedge lane, incl. thread pencil fitting to gear motor S37 ... at head drive station | | | |

Idler units

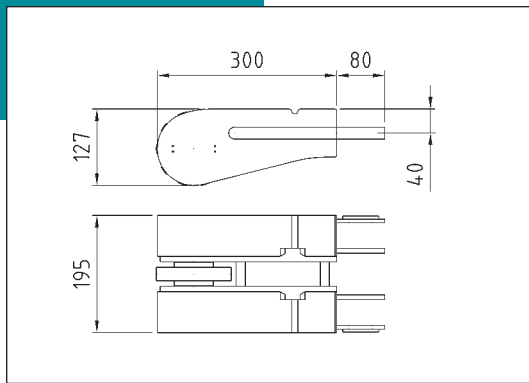
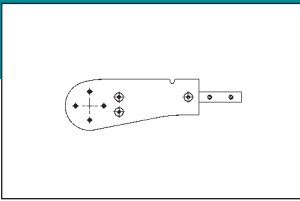

Description

Unit

Art. No.

RO-flex 195N

Idler 180°

1 pcs.

202701

PE/Stainless steel 1.4301
incl. fastening elements

Necessary chain length: 700 mm

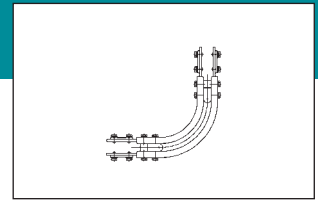

| | Description | Unit | Art. No. |
|--|---|---------------|---------------|
| | <p>RO-flex 195N</p> <p>Horizontal bend 30°</p> <p>PE/Stainless steel 1.4301, incl. fastening elements Radius R= 600 mm</p> <p>Necessary chain length: 990 mm</p> | <p>1 pcs.</p> | <p>203051</p> |
| | <p>RO-flex 195N</p> <p>Horizontal bend 45°</p> <p>PE/Stainless steel 1.4301, incl. fastening elements Radius R= 600 mm</p> <p>Necessary chain length: 1.300 mm</p> | <p>1 pcs.</p> | <p>203052</p> |
| | <p>RO-flex 195N</p> <p>Horizontal bend 60°</p> <p>PE/Stainless steel 1.4301, incl. fastening elements Radius R= 600 mm</p> <p>Necessary chain length: 1.620 mm</p> | <p>1 pcs.</p> | <p>203053</p> |

Horizontal bends

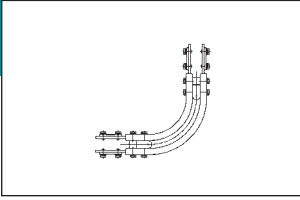

| | Description | Unit | Art. No. |
|--|--|--------|----------|
| | <p>RO-flex 195N</p> <p>Horizontal bend 90°</p> <p>PE/Stainless steel 1.4301, incl. fastening elements Radius R= 600 mm</p> <p>Necessary chain length: 2.250 mm</p> | 1 pcs. | 203054 |
| | <p>RO-flex 195N</p> <p>Horizontal bend 180°</p> <p>PE/Stainless steel 1.4301, incl. fastening elements Radius R= 600 mm</p> <p>Necessary chain length: 4.140 mm</p> | 1 pcs. | 203055 |

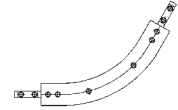

| | Description | Unit | Art. No. |
|--|---|--------|----------|
| | <p>RO-flex 195N</p> <p>Vertical bend 5°</p> <p>PE/Stainless steel 1.4301, incl. fastening elements Radius R= 600 mm</p> <p>Necessary chain length: 465 mm</p> | 1 pcs. | 203551 |
| | <p>RO-flex 195N</p> <p>Vertical bend 10°</p> <p>PE/Stainless steel 1.4301, incl. fastening elements Radius R= 600 mm</p> <p>Necessary chain length: 570 mm</p> | 1 pcs. | 203552 |
| | <p>RO-flex 195N</p> <p>Vertical bend 15°</p> <p>PE/Stainless steel 1.4301, incl. fastening elements Radius R= 600 mm</p> <p>Necessary chain length: 675 mm</p> | 1 pcs. | 203553 |

Vertical bends

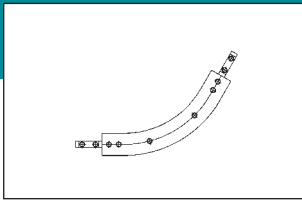

| | Description | Unit | Art. No. |
|--|---|--------|----------|
| | <p>RO-flex 195N</p> <p>Vertical bend 30°</p> <p>PE/Stainless steel 1.4301, incl. fastening elements Radius R= 600 mm</p> <p>Necessary chain length: 990 mm</p> | 1 pcs. | 203554 |
| | <p>RO-flex 195N</p> <p>Vertical bend 45°</p> <p>PE/Stainless steel 1.4301, incl. fastening elements Radius R= 600 mm</p> <p>Necessary chain length: 1.300 mm</p> | 1 pcs. | 203555 |
| | <p>RO-flex 195N</p> <p>Vertical bend 60°</p> <p>PE/Stainless steel 1.4301, incl. fastening elements Radius R= 600 mm</p> <p>Necessary chain length: 1.620 mm</p> | 1 pcs. | 203556 |

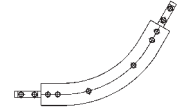

| | Description | Unit | Art. No. |
|--|--|---------------|---------------|
| | <p>RO-flex 195N</p> <p>Vertical bend 90°</p> <p>PE/Stainless steel 1.4301, incl. fastening elements Radius R= 600 mm</p> <p>Necessary chain length: 2.250 mm</p> | <p>1 pcs.</p> | <p>203557</p> |
| | <p>RO-flex 85/195</p> <p>Connecting strip E 20/5x140</p> <p>Stainless steel 1.4301 For the direct join of bends.</p> <p>Replace the premounted strips by the strips 101607. Reuse disassembled screws.</p> | <p>1 pcs.</p> | <p>101607</p> |

Content Accessories N

Supports

Page 68

Side guides

Page 73

Accessories, general

Page 86

Supports

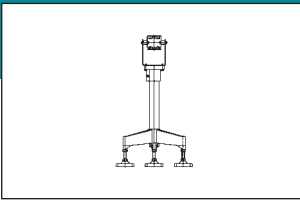

Support possibility System R60 (Tube ø60mm, stainless steel)

Support height H= 500-max.2000mm

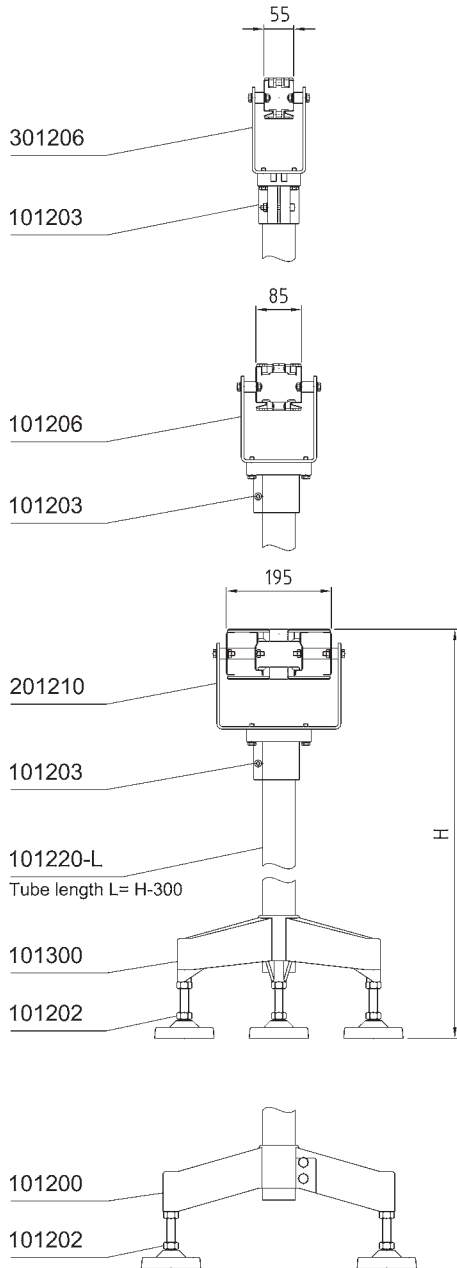

Support from head drive station

RO-flex-55 N

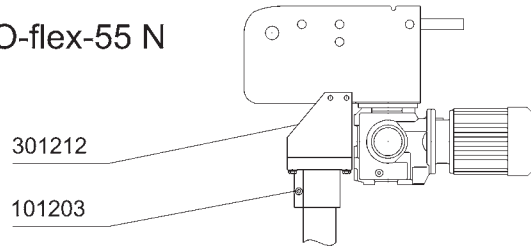

RO-flex-85 N

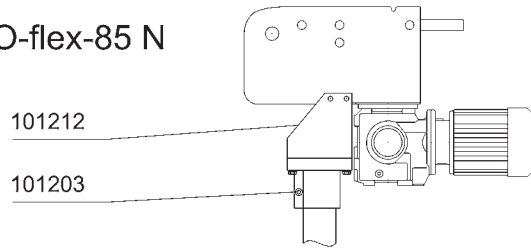

RO-flex-195 N

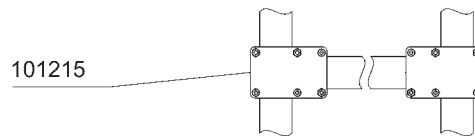
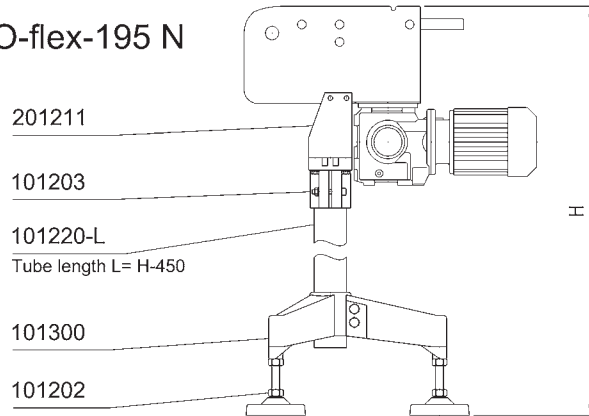

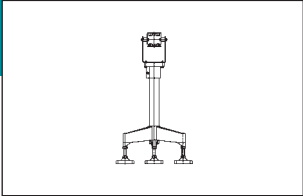

| | Description | Unit | Art. No. |
|--|--|--------|----------|
| | <p>RO-flex 55N/85N/195N</p> <p>Support tube cutting out R60-stainless steel</p> <p>Stainless steel 1.4301</p> <p>By order indicate wished length.</p> <p>Example for chassis support, inlet level H= 900 mm: with L= H- 300; L= 900- 300= 600 mm =Art. No. 101220-L600</p> | 1 pcs. | 101220-L |
| | <p>RO-flex 55/85/195</p> <p>2-legs support R60-ST2</p> <p>PA 6 black incl. fastening elements</p> | 1 pcs. | 101200 |
| | <p>RO-flex 55/85/195</p> <p>3-legs support R60-ST3</p> <p>PA 6 black incl. fastening elements</p> | 1 pcs. | 101300 |

Supports

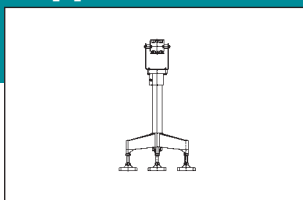

| | Description | Unit | Art. No. |
|--|---|--------|----------|
| | <p>RO-flex 55N/85N/195N</p> <p>Adjustable foot 110/M16-160N</p> <p>PA 6/Stainless steel 1.4301 incl. fastening elements</p> | 1 pcs. | 101202 |
| | <p>RO-flex 55/85/195</p> <p>Clamp piece R60-KL</p> <p>PA 6 black incl. fastening elements</p> | 1 pcs. | 101215 |
| | <p>RO-flex 55/85/195</p> <p>Header R60-KO</p> <p>PA 6 black incl. fastening elements</p> | 1 pcs. | 101203 |

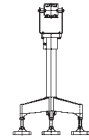

| | Description | Unit | Art. No. |
|--|--|--------|----------|
| | <p>RO-flex 55N</p> <p>Chassis supporting yoke R60-CH55N-assembly kit</p> <p>Stainless steel 1.4301 incl. fastening elements</p> | 1 pcs. | 301206 |
| | <p>RO-flex 55N</p> <p>Head drive yoke R60-KA55N-assembly kit</p> <p>Stainless steel 1.4301 incl. fastening elements</p> | 1 pcs. | 301212 |
| | <p>RO-flex 85N</p> <p>Chassis supporting yoke R60-CH85N-assembly kit</p> <p>Stainless steel 1.4301 incl. fastening elements</p> | 1 pcs. | 101206 |

Supports

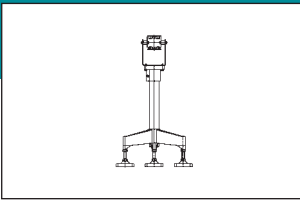

| | Description | Unit | Art. No. |
|--|---|--------|----------|
| | <p>RO-flex 85N</p> <p>Head drive yoke R60-KA85N-assembly kit</p> <p>Stainless steel 1.4301 incl. fastening elements</p> | 1 pcs. | 101212 |
| | <p>RO-flex 195N</p> <p>Chassis supporting yoke R60-CH195N-assembly kit</p> <p>Stainless steel 1.4301 incl. fastening elements</p> | 1 pcs. | 201210 |
| | <p>RO-flex 195N</p> <p>Head drive yoke R60-KA195N-assembly kit</p> <p>Stainless steel 1.4301 incl. fastening elements</p> | 1 pcs. | 201211 |

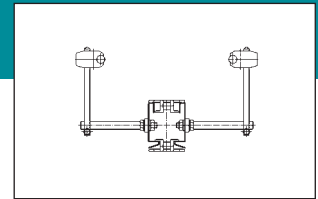

Side guide possibility System SF1-R12

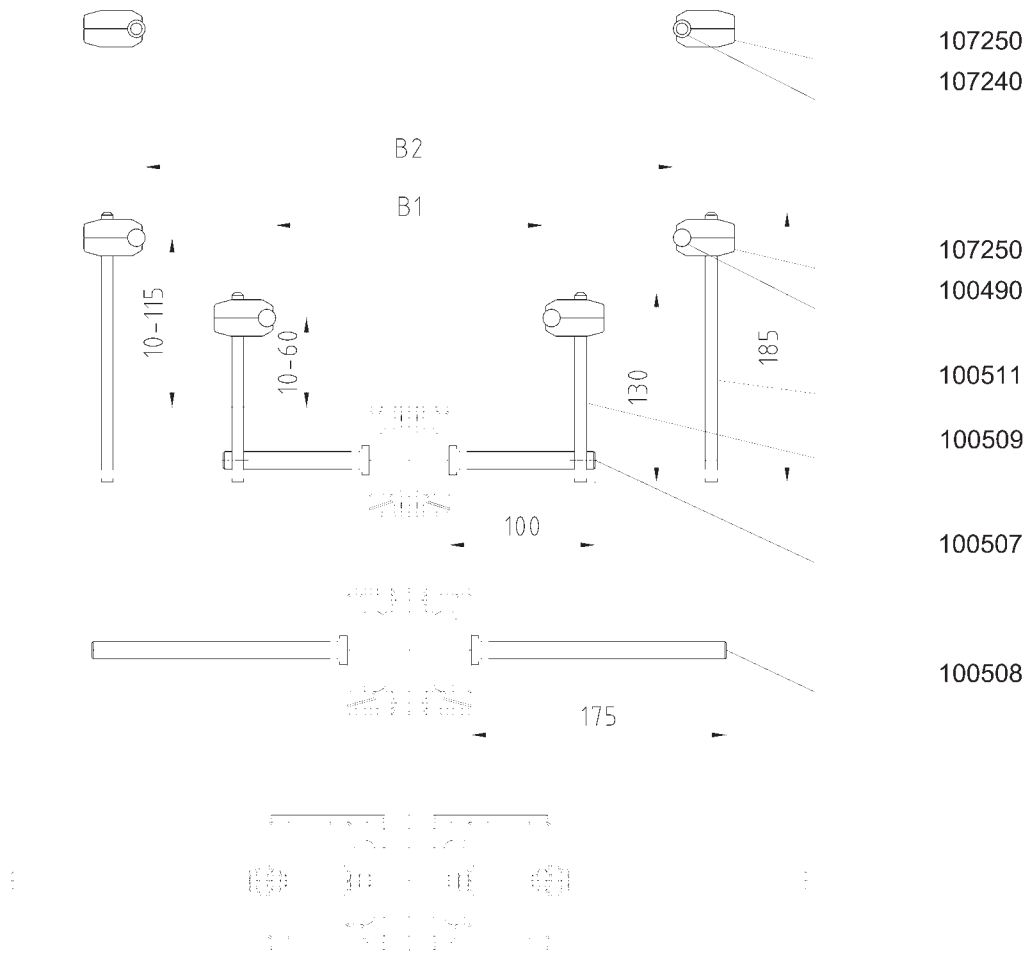

| guidance width (mm) | | RO-flex-55N | RO-flex-85N | RO-flex-195N |
|---------------------|--|-------------|-------------|--------------|
| B1 | | 100507 | 25 - 180 | 55 - 210 |
| B2 | | 100508 | - | 55 - 360 × |
| | | | | 165 - 320 |
| | | | | 165 - 470 |

* For product width B>250 provide product supports.

Side guides

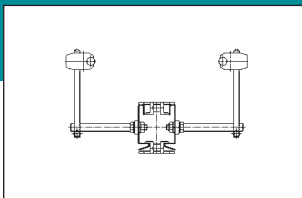

| | Description | Unit | Art. No. |
|--|---|--------|----------|
| | <p>RO-flex 55N/85N/195N</p> <p>Bracket SF1-12/100-assembly kit</p> <p>Stainless steel 1.4301 incl. fastening elements</p> | 1 pcs. | 100507 |
| | <p>RO-flex 85N/195N</p> <p>Bracket SF1-12/175-assembly kit</p> <p>Stainless steel 1.4301 incl. fastening elements</p> | 1 pcs. | 100508 |
| | <p>RO-flex 55N/85N/195N</p> <p>Clamp holder SF1-130</p> <p>Stainless steel 1.4301 incl. fastening elements</p> | 1 pcs. | 100509 |

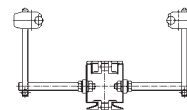

| | Description | Unit | Art. No. |
|--|--|--------|----------|
| | <p>RO-flex 55N/85N/195N</p> <p>Clamp holder SF1-175</p> <p>Stainless steel 1.4301 incl. fastening elements</p> | 1 pcs. | 100511 |

Side guides

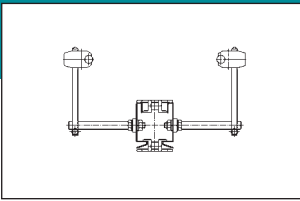

Side guide possibility System SF2-R12

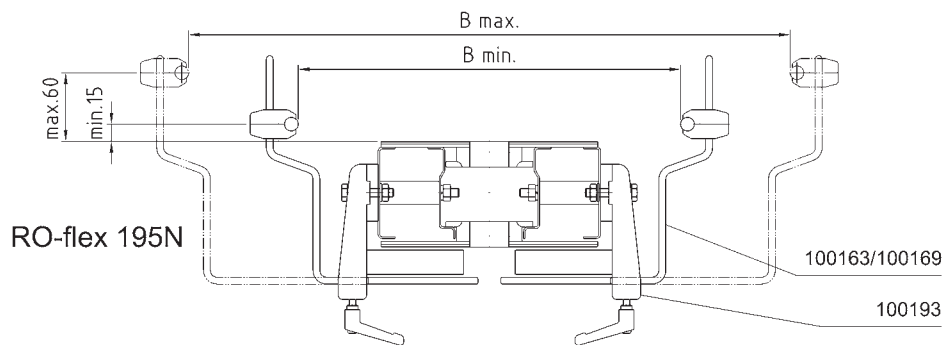
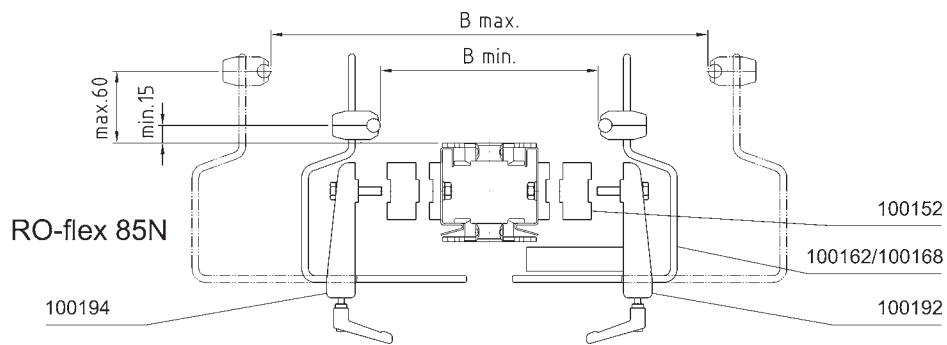
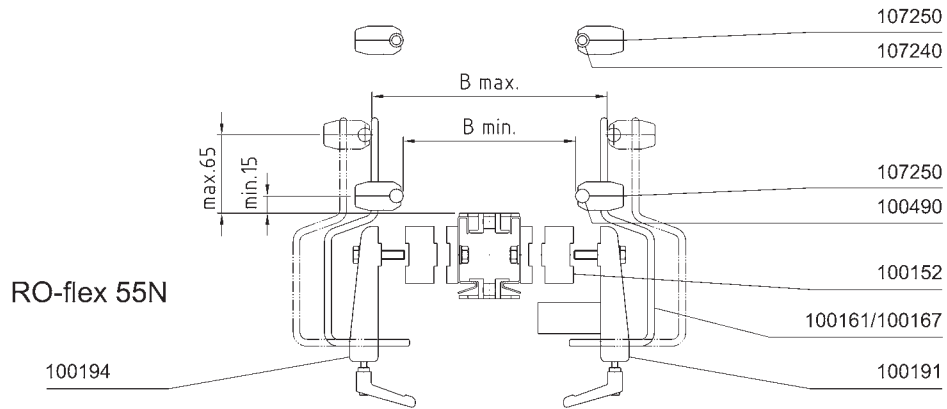

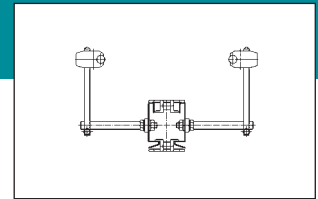

guidance width (mm):

| Yoke typ: | Spacer 100152: number per side | RO-flex-55N B | RO-flex-85N B | RO-flex-195N B |
|----------------------|-----------------------------------|------------------|----------------------------|-------------------|
| Yoke K | without | 11 - 70 | 41 - 100 | 151 - 210 |
| with scale 100161 | 1 pcs. | 61 - 120 | 91 - 150 | 201 - 260 |
| without scale 100167 | 2 pcs. | - | 141 - 200 | 251 - 310 |
| Yoke M | without | - | 41 - 240 ²⁾ | 151 - 350 |
| with scale 100162 | 1 pcs. | - | 91 - 290 ^{1) 2)} | 201 - 400 |
| without scale 100168 | 2 pcs. | - | 151 - 340 ¹⁾ | 251 - 450 |
| Yoke L | without | - | 205 - 405 ^{1) 3)} | 315 - 515 |
| with scale 100163 | 1 pcs. | - | 255 - 455 ^{1) 3)} | 265 - 565 |
| without scale 100169 | 2 pcs. | - | 315 - 505 ¹⁾ | 415 - 615 |

¹⁾ For product width B>250 provide product supports.

Assembly instruction: (only for RO-flex 85)

²⁾ For product width B<151mm bracket shall be moved for 40mm.

³⁾ For product width B<315mm bracket shall be moved for 40mm.

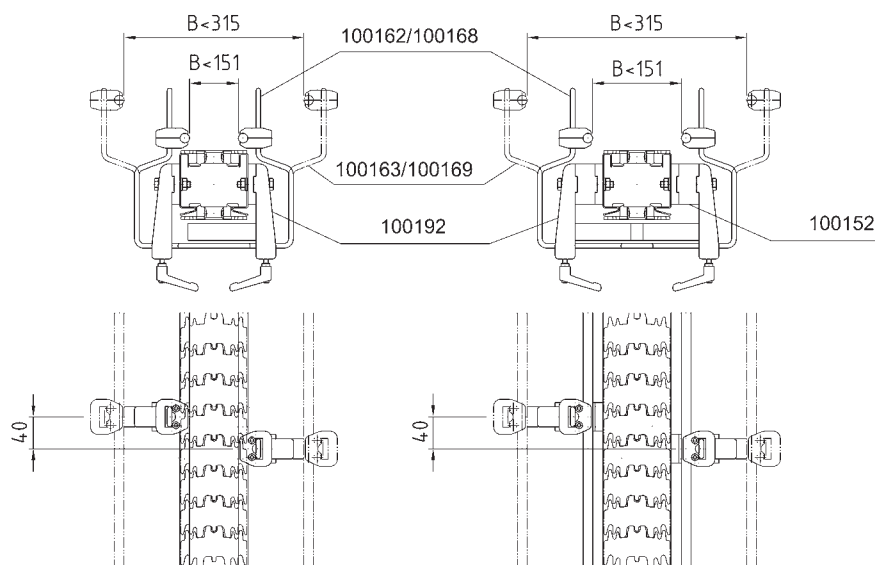

Side guides

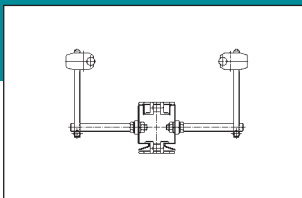

| | Description | Unit | Art. No. |
|--|---|--------|----------|
| | <p>RO-flex 55N</p> <p>Side guide holder SF2-55N-assembly kit</p> <p>PA 6/Stainless steel 1.4301 incl. fastening elements and protection</p> | 1 pcs. | 100191 |
| | <p>RO-flex 85N</p> <p>Side guide holder SF2-85N-assembly kit</p> <p>PA 6/Stainless steel 1.4301 incl. fastening elements and protection</p> | 1 pcs. | 100192 |
| | <p>RO-flex 195N</p> <p>Side guide holder SF2-195N-assembly kit</p> <p>PA 6/Stainless steel 1.4301 incl. fastening elements and protection</p> | 1 pcs. | 100193 |

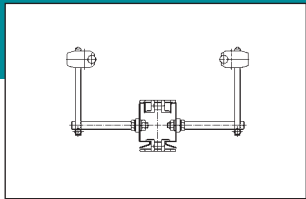

| | Description | Unit | Art. No. |
|--|---|--------|----------|
| | <p>RO-flex 55N/85N/195N</p> <p>Side guide holder SF2-0N-assembly kit</p> <p>PA 6/Stainless steel 1.4301 incl. fastening elements without protection</p> | 1 pcs. | 100194 |
| | <p>RO-flex 55/85/195</p> <p>Spacer SF2-25</p> <p>PA 6 black</p> | 1 pcs. | 100152 |
| | <p>RO-flex 55N/85N/195N</p> <p>Fastening bracket SF2-N</p> <p>PA 6 black</p> | 1 pcs. | 100153 |

Side guides

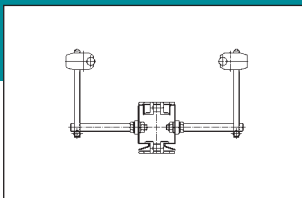

| | Description | Unit | Art. No. |
|--|---|--------|----------|
| | <p>RO-flex 55N/85N/195N</p> <p>Short yoke SF2-K</p> <p>Stainless steel 1.4301</p> | 1 pcs. | 100167 |
| | <p>RO-flex 85N/195N</p> <p>Middle yoke SF2-M</p> <p>Stainless steel 1.4301</p> | 1 pcs. | 100168 |
| | <p>RO-flex 85N/195N</p> <p>Long yoke SF2-L</p> <p>Stainless steel 1.4301</p> | 1 pcs. | 100169 |

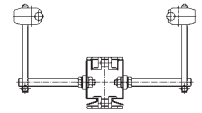

| | Description | Unit | Art. No. |
|--|--|--------|----------|
| | RO-flex 55N/85N/195N Short yoke with scale SF2-K+M Stainless steel 1.4301 | 1 pcs. | 100161 |
| | RO-flex 85N/195N Middle yoke with scale SF2-M+M Stainless steel 1.4301 | 1 pcs. | 100162 |
| | RO-flex 85N/195N Long yoke with scale SF2-L+M Stainless steel 1.4301 | 1 pcs. | 100163 |

Side guides

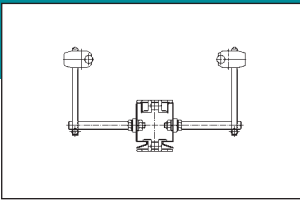

Side guide possibility System SF3

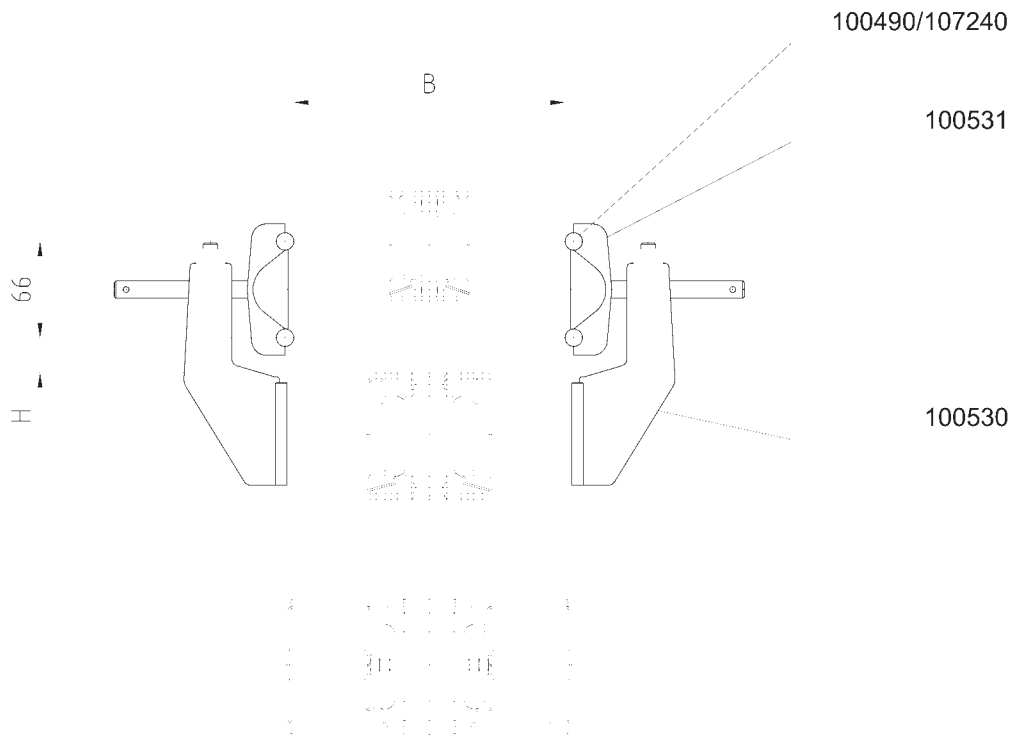

| | RO-flex-55N | RO-flex-85N | RO-flex-195N |
|-----------------------|-------------|-------------|--------------|
| guidance width B (mm) | 0 - 80 | 0 - 110 | 85 - 220 |
| Height H (mm) | 29 | 24 | 23 |

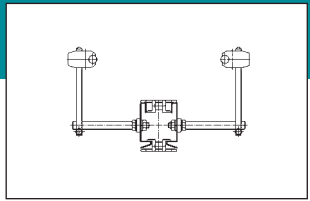

| | Description | Unit | Art. No. |
|--|--|--------|----------|
| | <p>RO-flex 55N/85N/195N</p> <p>Side guide holder SF3-N-Kit</p> <p>PA 6/Stainless steel 1.4301 incl. fastening elements</p> | 1 pcs. | 100530 |
| | <p>RO-flex 55/85/195</p> <p>Double clamp SF3</p> <p>PA 6/Stainless steel 1.4301</p> | 1 pcs. | 100531 |
| | <p>RO-flex 55/85/195</p> <p>Guide profile $\phi 12$ R12</p> <p>Stainless steel 1.4301</p> <p>Length = 3.000 mm</p> | 1 pcs. | 100490 |

Side guides

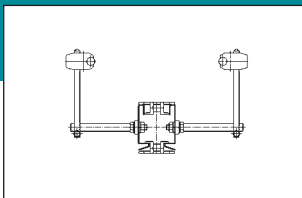

| | Description | Unit | Art. No. |
|--|---|--------|----------|
| | <p>RO-flex 55/85/195</p> <p>Polymer coated guide profile R12-KU</p> <p>Stainless steel 1.4301/HDPE grey</p> <p>Length = 3.000 mm</p> | 1 pcs. | 107240 |
| | <p>RO-flex 55/85/195</p> <p>End cap to guide profile R12-KU</p> <p>HDPE grey</p> | 1 pcs. | 107242 |
| | <p>RO-flex 55/85/195</p> <p>Clamp to guide profile R12</p> <p>PA 6 black incl. fastening elements</p> | 1 pcs. | 107250 |

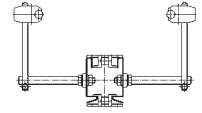

| | Description | Unit | Art. No. |
|--|--|--------|----------|
| | <p>RO-flex 55/85/195</p> <p>Connecting sleeve R12-assembly kit</p> <p>Stainless steel 1.4301 incl. fastening elements</p> | 1 pcs. | 107252 |
| | <p>RO-flex 85N</p> <p>Bracket for produkt support R12-N-assembly kit</p> <p>Stainless steel 1.4301 incl. fastening elements</p> | 1 pcs. | 100540 |

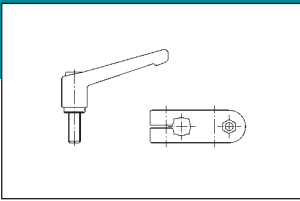

| | Description | Unit | Art. No. |
|--|---|--------|----------|
| | <p>RO-flex 55N/85N/195N</p> <p>Connector strip type B Assembly kit</p> <p>Stainless steel 1.4301 incl. fastening elements</p> <p>For connection of chassis to RO-flex ALUMINIUM-components at Chassis RO-flex Stainless steel.</p> | 1 pcs. | 101604 |
| | <p>RO-flex 55/85/195</p> <p>Cross clamp R12</p> <p>PA 6 black incl. fastening elements</p> | 1 pcs. | 100532 |
| | <p>RO-flex 55/85/195</p> <p>Threaded chuck M6x16 outside</p> <p>Stainless steel 1.4301, RAL 2004 orange</p> | 1 pcs. | 100155 |

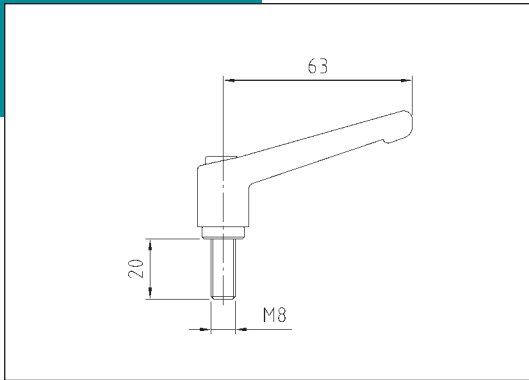
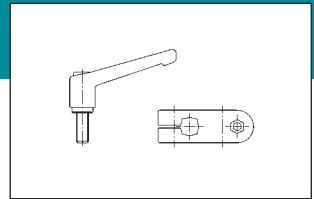

Description

Unit

Art. No.

RO-flex 55/85/195

**Threaded chuck
M8x20 outside**

Stainless steel 1.4301, RAL 2004 orange

1 pcs.

100156

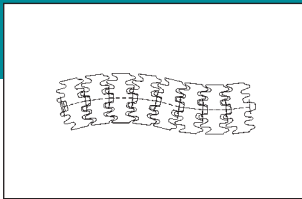

Chassis

The chassis for the RO-flex stainless steel conveyors are delivered as straight cut profiles, in pairs in lengths of 3m or 2m.

The RO-flex chains from wear-free plastic allow the direct low-friction running on the bearing surfaces integrated in the chassis.

The stainless chassis profiles are provided with continuous punch holes, spacing 40mm, which allows for the assembly of attachment parts like side guide holders, supports, etc. without drilling. All attachment parts and connecting elements are compatible with this punch hole spacing.

The actually required chassis lengths may be cut to length from the standard lengths at a spacing of 40mm. After sawing, the chassis ends must be bevelled at the upper and lower drum in running direction of the RO-flex chain. For the assembly of the chassis, the chassis profile pairs are screwed together using cross links or distance kits in intervals of approx. 500mm.

Tools

For drilling the correct hole spacing at the chassis end (after cutting to length in deduction of the 40mm spacing), a drilling jig is available.

Chassis connections

For linking several chassis elements, screwable strapped joints or connecting straps are available.

The connecting elements for the uplink of drive stations, arc bends, continuous bends and deflections are included in the scope of delivery of the related component.

Specifications

Material: chassis profile stainless steel 1.4301

Weights:

| | |
|---------------------------------------|----------|
| chassis RO-flex 55N, fully assembled | 2.1 kg/m |
| chassis RO-flex 85N, fully assembled | 2.6 kg/m |
| chassis RO-flex 195N, fully assembled | 6.0 kg/m |

Deflection:

RO-flex 55N 2 mm deflection authorized, at lumped load 10 kg, support distance 2 m
2 mm deflection authorized, at area load 10 kg/m, support distance 2 m

RO-flex 85N 2 mm deflection authorized, at lumped load 20 kg, support distance 2 m
2 mm deflection authorized, at area load 20 kg/m, support distance 2 m

RO-flex 195N 2 mm deflection authorized, at lumped load 50 kg, support distance 2 m
2 mm deflection authorized, at area load 50 kg/m, support distance 2 m

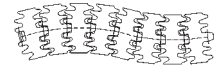

Chains

The horizontal and vertical curve-going chains RO-flex 55, RO-flex 85 and RO-flex 195 consist of wear and impact resistant POM plastic and stainless connecting bolts.

The systems RO-flex 55 and RO-flex 85 are equipped with geared chain links. The toothing offers 2 essential advantages:

- On straight lines, in curves as well as during drive and idler, the gap between the chain links does not bear the risk of accidents.
- Even the smallest parts (up to Ø 16 mm) may be conveyed or pushed on/off without any problem even in accumulating operation.

The chains RO-flex 195 are designed in a way that no risk of accidents occurs even in the curves through the chain plates opening.

To be able to convey the most different products also on ascending and descending slopes or even vertically, a multitude of belt cleats types are available. For detailed information, please, see the related chapter or call us for information.

Specifications

Material: chain POM white, other RAL colours available upon request.
bolt, stainless steel 1.4301

Temperatures operation between -40°C and +90°C

| | | |
|----------------|-------------|-----------|
| Weights | RO-flex 55 | 0.44 kg/m |
| | RO-flex 85 | 1 kg/m |
| | RO-flex 195 | 2 kg/m |

| | | |
|----------------------|-------------|---------|
| Tensile force | RO-flex 55 | 1,000 N |
| | RO-flex 85 | 2,200 N |
| | RO-flex 195 | 4,000 N |

| | | |
|------------------------|-------------|-----|
| Packaging units | RO-flex 55 | 3 m |
| | RO-flex 85 | 3 m |
| | RO-flex 195 | 5 m |

| | | | |
|-------------------|------------|-------------|--------|
| Radii min. | horizontal | RO-flex 55 | 125 mm |
| | | RO-flex 85 | 200 mm |
| | | RO-flex 195 | 600 mm |
| | vertical | RO-flex 55 | 300 mm |
| | | RO-flex 85 | 400 mm |
| | | RO-flex 195 | 600 mm |

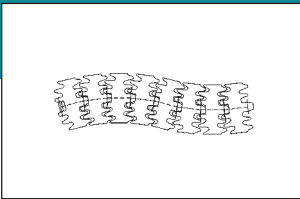

Drive stations

Head drive stations are to be used preferably.

The head drive stations are installed at the end of the conveyor in conveying direction. The notation “right” and “left” refer to the configuration of the chain drive, viewed in conveying direction, with the motor at the bottom.

In addition to the head drives, center drives may be delivered. Please see the various chapters for further information and specifications.

All drive stations may be delivered with or without motor. In both cases, the related motor plates for SEW S37 are included in the scope of delivery. Adapter plates for other motors available upon request.

For the design of the motor, we need speed, load and track routing of the conveyor. We provide example calculations upon request.

Specifications

Possible conveying speeds: $V = 6 - 60 \text{ m/min}$

Possible motor output: $P =$
 0.18 KW
 0.25 KW
 0.37 KW
 0.55 KW

Material: stainless steel 1.4301 / PE

Chain wheels: head drives are driven using chain wheels and roller chain. For the required chain wheels, please, see chapter Drive.

Design of the motor speed for head drive stations

Speed of the drive motor

Notation used:

V = conveying speed (m/sec)
 Z_M = number of teeth of the chain wheel – gear motor
 Z_A = number of teeth of chain wheel – drive station
 N_{ab} = output speed of the gear motor (rpm)

Calculation RO-flex 55N

$$N_{ab} = 215 \times V \times Z_A / Z_M \quad (\text{rpm})$$

Calculation RO-flex 85N and RO-flex 195N

$$N_{ab} = 155 \times V \times Z_A / Z_M \quad (\text{rpm})$$

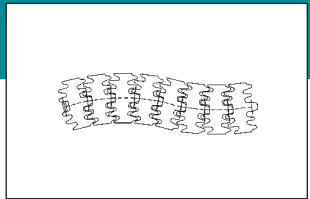

Idler units

In case of head drive stations, the idler units are installed at the end of the conveyor opposite to the conveying direction.

In case of centre drives, 2 idler units are required.

At the idler unit, an additional opening for the assembly/disassembly of the chain is provided.

Specifications:

Material: steel, stainless 1.4301 / PE

Horizontal wheel bends

Horizontal direction changes with small radii should be made using wheel bends wherever possible. Through the ball bearing supported idler plates, the friction forces and thus wear and chain tensile force are extremely low. The installation space required must be taken into consideration when planning the system.

The connecting strips for the connection to a chassis profile are included in the scope of delivery.

The required guide rails must be ordered separately.

Specifications

Material: stainless steel 1.4301/ PA 6

Radius: horizontal RO-flex 55N 125 mm
RO-flex 85N 200 mm

Planning notes:

RO-flex-55N

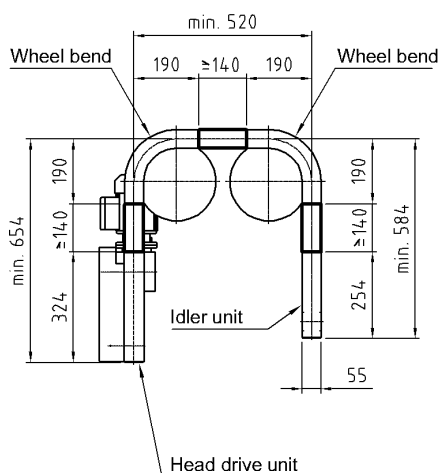

RO-flex-85N

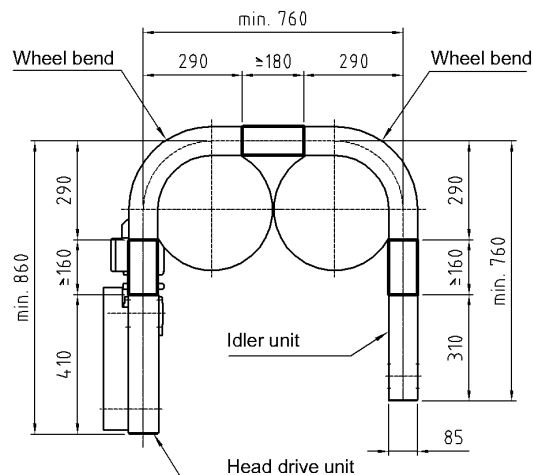

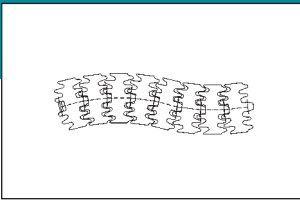

Bends

Horizontal bends

The horizontal bends are composed of solid PE material with an extremely low friction value against the chain material.

Despite of this, horizontal bends should only be used for the systems RO-flex 55N and RO-flex 85N if the use of wheel bends is impossible.

The connecting strips for the connection to the chassis profile are included in the scope of delivery.

For the connection of horizontal continuous bends to other components, please, observe the following planning notes.

Specifications

Material: steel, stainless 1.4301 / PE

| | | | |
|----------------|------------|--------------|-------------------|
| Radius: | horizontal | RO-flex 55N | 125 mm |
| | | RO-flex 85N | 200 mm and 500 mm |
| | | RO-flex 195N | 600 mm |

Other radii available upon request

| | | | |
|---------------|------------|--------------|-------------------------------|
| Angle: | horizontal | RO-flex 55N | 30°, 45°, 60°, 90° |
| | | RO-flex 85N | 15°, 30°, 45°, 60°, 90°, 180° |
| | | RO-flex-195N | 30°, 45°, 60°, 90°, 180° |

Planning notes:

RO-flex-55N

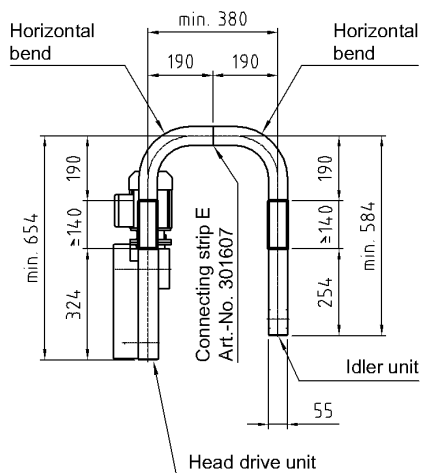

RO-flex-85N

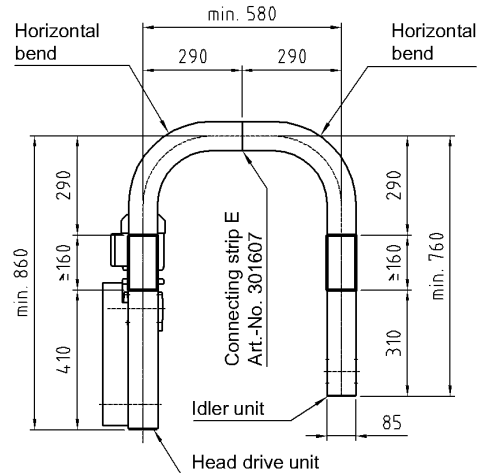

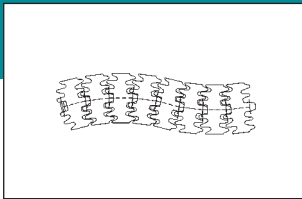

Supports

To support the conveyors, 2-leg and 3-leg supports are available. The support length may be defined using the pipe length, fine adjustment can be made using the threaded bars at the adjusting feet. The adjusting feet may be dowelled down.

Specifications

| | | |
|-------------------------|--|--|
| Material: | 2-leg/3-leg support pipe fastening elements | PA6 / stainless steel, stainless steel PA6 / stainless steel |
| Support heights: | 2-leg/3-leg supports | H = 400 – 2,000 mm |

Side guides

The design of the side guides varies and depends on the product to be conveyed and the conveying situation. As standard, 3 side guide profiles are available for this purpose.

Using the elements offered, fixed, adjustable and variable side guides for most of the product shapes and sizes may be realized.

Specifications

| | |
|----------------|---|
| Models: | side guide profile Ø 12 mm, stainless steel 1.4301 |
| | side guide profile Ø 12/8 mm, stainless steel 1.4301 / PA |

Order information: The intervals and thus the number of side guide holders depend on the conveying situation. In case of accumulating operation, a distance of 0.3 – 0.5 m may be necessary, in case of normal transport operation, intervals of 1 – 1.5 m may be sufficient.

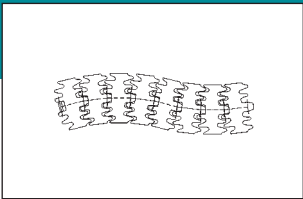

The following descriptions and calculations are meant as support to give you a survey of the following subjects:

- Systems and fields of application
- Calculations of chain tensile force and motor output
- Materials in the RO-flex conveying systems with mechanical, physical and chemical characteristics

SYSTEMS AND FIELDS OF APPLICATION

1. RO-flex 55N, RO-flex 85N and RO-flex 195N

Depending on the size and weight of the products to be conveyed, three different conveying widths - 55mm, 85mm or 195mm – may be used. Here, the material to be conveyed may have four times the width of the conveyer width. Depending on the position of the center of gravity, the products to be conveyed must additionally be leaded at the side. The weight of the conveyed products is taken into account when calculating tensile force and motor output.

2. RO-flex ALUMINIUM (separate catalog)

The RO-flex ALUMINIUM model is mainly used in **normal, dry environment** for packed products and with PVDF guide rail also in oily surroundings.

To all system widths, the following material specifications apply:

- profiles (chassis, supports, side guides, etc): aluminium anodized
- steel parts and components: St 37, St 50, electro galvanized

3. RO-flex STAINLESS STEEL

For **wet areas** and environments with increased hygienic requirements, as e.g. chemical, pharmaceutical and food industry, a complete program in stainless steel design, offering the same system widths, is available.

CALCULATION OF CHAIN TENSILE FORCE AND MOTOR OUTPUT

When determining the conveying lengths and routings of RO-flex conveyors, it is important that the generated **TENSILE FORCE** and **MOTOR OUTPUT** are calculated. Through the correct dimensioning of the conveyer, the motor output may be optimized thus avoiding increased wear.

Notation used

| | | | |
|---|-------|--|---------|
| F_K = chain tensile force | [N] | k_α = bend factor | |
| L = conveying length | [m] | F_{zul} = max.perm. tensile force | [N] |
| = chain weight * | [N/m] | P_M = drive motor output | [kW] |
| = product weight w/o accumulation* | N/m] | v = conveying speed | [m/sec] |
| q_{FS} = product weight w/ accumulation * | [N/m] | S = safety factor | |
| μ_1 = friction coefficient-guide rail | | Z_A = teeth number chain wheel drive station | |
| μ_2 = friction coefficient-conveyed product | | Z_M = teeth number chain wheel gear motor | |
| α = angle of horizontal bend | | n_{ab} = output speed of gear motor | [rpm] |
| β = angle of vertical bend | | | |

* uniform loads

Specifications

Table 1

| Chain type | Material | Chain weight [N/m] | Max.perm. tensile force [N] |
|--------------|----------|--------------------|-----------------------------|
| RO-flex 55N | POM | 4 | 1,000 |
| RO-flex 85N | POM | 10 | 2,250 |
| RO-flex 195N | POM | 25 | 4,000 |

Table 2

| Bend type | Bend factor k_α |
|--|------------------------|
| Vertical and horizontal continuous bends | |
| 5° - 30° | 1.2 |
| 45° | 1.3 |
| 60° | 1.4 |
| 90° | 1.6 |
| 180° | 2.6 |
| Horizontal wheel bends (with ball bearing) | |
| 30° - 60° | 1.02 |
| 60° - 90° | 1.05 |
| 180° | 1.1 |
| Drive stations, idler units (with ball bearing) | |
| Drive station | 1.05 |
| Idler | 1.05 |

Subject to technical changes!

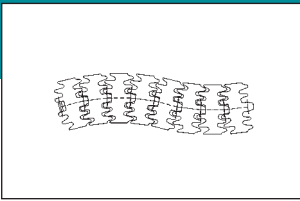

Table 3

| Chain material | Lubrication | Friction coefficient μ_1 | | | Friction coefficient μ_2 | | | |
|----------------|---------------|------------------------------|------|---------------------------|--------------------------------|-------|------------|---------|
| | | Chain guide rail | | Chain - chassis stainless | Chain – product to be conveyed | | | |
| | | Material of guide rail | | | Material on conveying belt | | | |
| | | PVDF | HDPE | | Steel | Glass | Card-board | Plastic |
| POM | dry | 0.2 | 0.15 | 0,2 | 0.2 | 0.15 | 0.25 | 0.2 |
| | water | 0.15 | 0.15 | 0,2 | 0.15 | 0.15 | - | 0.15 |
| | Silicon spray | 0.1 | 0.1 | 0,15 | - | - | - | - |
| | oil | 0.1 | - | 0,1 | 0.1 | - | - | - |

These values are meant as reference values only and must be recalculated and determined specifically in extreme cases and in cases of doubt.

Chain tensile force

The chain tensile force generated results from the frictional forces which occur under the varying conveying situations and conditions. In order to avoid overload on the chain, the following must be true

$$F_{zul} \geq F_K$$

The following different conveying situations and conditions must be taken into account:

1. Conveyance without accumulation

Frictional force between RO-flex chain and guide rail or chassis with products to be conveyed loaded.

$$F_K = L \cdot (2 \cdot q_K + q_F) \cdot \mu_1$$

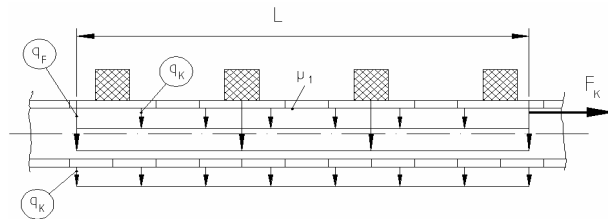

2. Conveyance with accumulation

In addition to point 1., the frictional force acts between the RO-flex chain and the accumulated conveyed products.

$$F_K = L \cdot [(2 \cdot q_K + q_F) \cdot \mu_1 + q_{Fs} \cdot \mu_2]$$

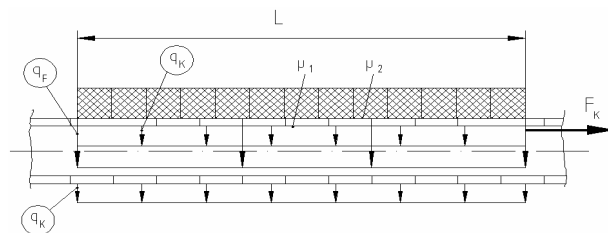

3. Conveyance with belt cleats

In case of ascending conveyers with angle of inclination $\beta > 5^\circ$, the products to be conveyed must be taken either by belt cleats or on friction chain. In this way, the gravitational force matching the inclination angle is put on the products to be conveyed or their frictional force is reduced proportionally.

$$F_K = L \cdot (2 \cdot q_K + q_F) \cdot (\mu_1 \cdot \cos\alpha \cdot \sin\beta)$$

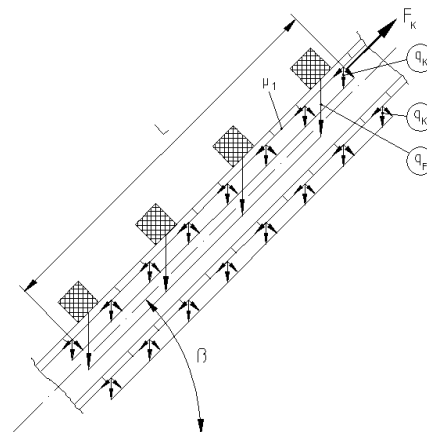

Subject to technical changes!

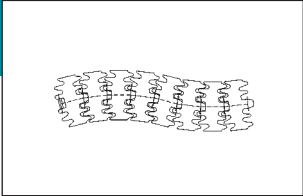

4. Bend factor

As the frictional force and thus the chain tensile force increasing at each changes of the direction, the conveyor must be split up in segments. After each segment, the calculated chain tensile force is multiplied by k_α (s. table 2).

Calculation – chain tensile force

A conveyor with 'n' bends (direction changes) is divided up into 'n+1' segments. One segment always ends after one bend. The tensile forces at the related ends of the bends are added up where the first segment is the one the furthest away from the drive. The tensile force increase through drive and idler is taken into account by multiplying the calculated tensile force by the accumulated bend factor 1,1.

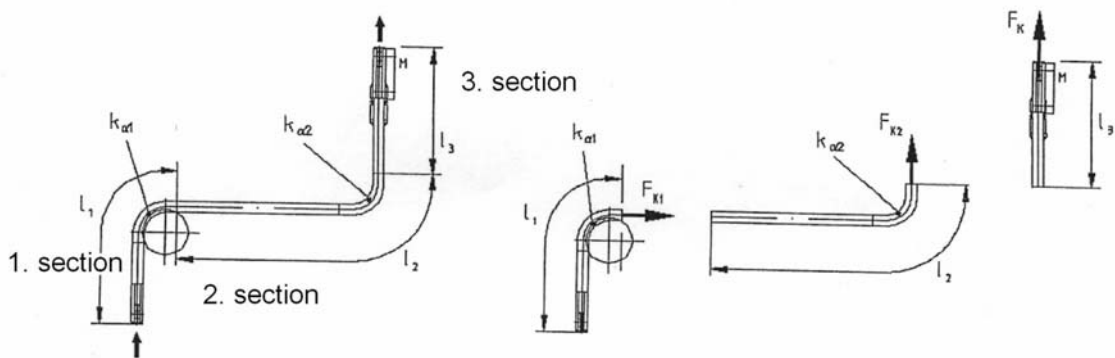

$$F_k = 1,1 \cdot \{ [(F_{k1} \cdot k_{\alpha1} + F_{k2}) \cdot k_{\alpha2} + F_{k3}] \cdot k_{\alpha3} + F_{k4} \} \cdot k_{\alpha4} \dots$$

Calculation – motor output

Motor output

The motor output P_M is calculated in accordance with the following formula:

$$P_M = \frac{S \cdot F_k \cdot v}{1,000} \text{ [kW]}$$

The **safety factor S** takes into account unknown operation conditions (contamination, temperature, or similar) and can be set to $S = 1.5 \dots 2.5$.

Speed (RO-flex 55N)

The output speed n_{ab} of the gear motor is calculated in accordance with the following formula:

$$n_{ab} = 215 \cdot v \cdot \frac{Z_A}{Z_M} \text{ [rpm]}$$

Speed (RO-flex 85N and 195N)

The output speed n_{ab} of the gear motor is calculated in accordance with the following formula:

$$n_{ab} = 155 \cdot v \cdot \frac{Z_A}{Z_M} \text{ [rpm]}$$

Subject to technical changes!

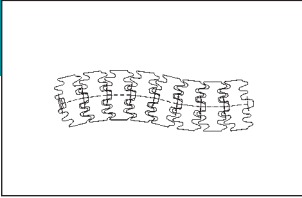

Example calculation RO-flex 85N conveyor with accumulation track

$n = 2$ bends \Rightarrow 3 segments !

Given data :

Product to be conveyed: cardboard boxes $m = 2$ kg
 $l^*w^*h = 250^*200^*100$
 25 pcs/min

$$v = 0.4 \text{ m/sec}$$

$$l_{ges} = 19.5 \text{ m}$$

$$l_1 = 6.5 \text{ m}$$

$$l_2 = 9.2 \text{ m}$$

$$l_3 = 3.8 \text{ m (accumulation track)}$$

Chain: RO-flex 85 POM $\Rightarrow q_K = 10$ N/m

friction coefficient: HDPE (dry run)

$$\Rightarrow \mu_1 = 0.15$$

w/o accumulation: $\Rightarrow q_F \approx 20$ N/m

w/ accumulation: $\Rightarrow q_{FS} \approx 80$ N/m

$$\Rightarrow \mu_2 = 0.25$$

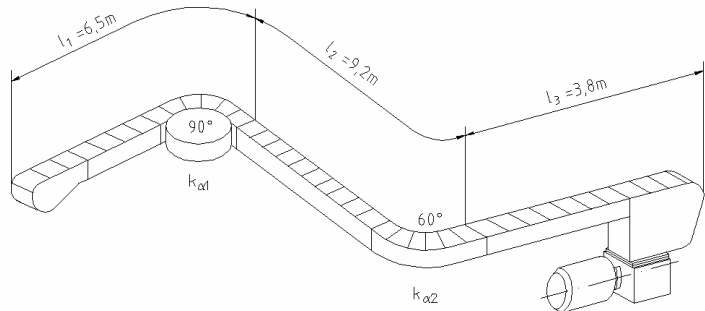

Chain tensile force

$$F_K = 1.1 \cdot [(F_{K1} \cdot k_{\alpha1} + F_{K2}) \cdot k_{\alpha2} + F_{K3}] \cdot k_{\alpha3}$$

1st section w/o accumulation

$$F_{K1} = l_1 \cdot (2q_K + q_F) \cdot \mu_1$$

$$\mu_1 = 0.15, \text{ from table 3}$$

$$F_{K1} = 6.5 \cdot (2 \cdot 10 + 20) \cdot 0.15 = 39 \text{ N}$$

2nd section w/o accumulation

$$F_{K2} = l_2 \cdot (2q_K + q_F) \cdot \mu_1$$

$$F_{K2} = 9.2 \cdot (2 \cdot 10 + 20) \cdot 0.15 = 55.2 \text{ N}$$

3rd section w/ accumulation

$$F_{K3} = l_3 \cdot [(2q_K + q_{FS}) \cdot \mu_1 + q_{FS} \cdot \mu_2]$$

$$\mu_2 = 0.25, \text{ from table 3}$$

$$F_{K3} = 3.8 \cdot (2 \cdot 10 + 90) \cdot 0.15 + 90 \cdot 0.25 = 148 \text{ N}$$

with $k_{\alpha1} = 1.05$ and $k_{\alpha2} = 1.6$, from table 2

$$\Rightarrow F_K = 1.1 \cdot [(39 \cdot 1.05 + 55.2) \cdot 1.6 + 148] = 332 \text{ N}$$

$$\text{with } F_{zul} = 2250 \text{ N} \Rightarrow F_K < F_{zul}$$

Motor output

$$P_M = \frac{S \cdot F_K \cdot v}{1,000} \text{ [kW]} = \frac{2.5 \cdot 332 \cdot 0.4}{1,000} = 0.332 \text{ kW}$$

$$P_M = 0.332 \text{ kW} \Rightarrow \text{selected } P_M = 0.37 \text{ kW}$$

Speed

$$n_{ab} = 155 \cdot v \cdot \frac{Z_A}{Z_M} \text{ [rpm]} = 155 \cdot 0.4 \cdot \frac{19}{19} = 62 \text{ rpm}$$

Subject to technical changes!

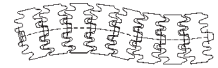

Materials in the RO-flex Conveying Systems

The following table includes the most important mechanical and physical characteristics

| Material: | Density kg/m ³ | E module N/mm ² | Tensile strength N/mm ² | Water absorption % |
|---|------------------------------|-------------------------------|---------------------------------------|-----------------------|
| Aluminium anodized AlMgSi 0,5 / F25 | 2,700 | 65,000 | 280 | - |
| Steel electro galvanized St 37 | 7,850 | 210,000 | 390 | - |
| Steel stainless Wst.No. 1.4301 | 7,900 | 200,000 | 500 | - |
| Polyamide fiber glass reinforced PA 6.6 - 30GF | 1,360 | 8,000 | 180 | 6.6 |
| Polycarbonate fiber glass reinforced PC - 30GF | 1,430 | 5,500 | 75 | 0.3 |
| Polyethylene high-molecular HDPE | 950 | 1,000 | 25 | 0.02 |
| Polypropylene calcium reinforced PP - 40CA | 1,160 | 1,500 | 40 | 0.03 |
| Acetal , POM | 1,410 | 3,000 | 70 | 0.8 |
| Polyvinyl chloride , PVC | 1,440 | 3,100 | 54 | 0.04 |
| Polyvinylidene fluoride , PVDF | 1,780 | 1,800 | 50 | 0.1 |
| Polystyrene , PS | 1,050 | 3,300 | 50 | 0.5 |

Temperature limit values in operation - 40°C to + 90°C

The operational temperature limit values are determined by the plastics used for chains and guide rail. They may change under defined operation conditions. When operating the conveyor close to the temperature limits, the values in the table above may also change under certain circumstances, as do motor and wear. In particular cases, please, contact us for further consulting.

Resistance to Chemicals

| Chemical: | Active ingredient | | | | | | | | |
|-------------------|-------------------|---------|------|---------|-----|-----|------|----|-----------------|
| | PA 6.6-30GF | PC-30GF | HDPE | PP-40Ca | POM | PVC | PVDF | PS | Stainless steel |
| Acetone | a | c | a | a | a | - | b | c | a |
| Formic Acid | a | b | a | a | c | a | a | a | b |
| Ammonia , 50% | - | c | a | a | a | a | a | a | a |
| Amyle alcohol | - | a | a | a | c | a | a | a | b |
| Aniline | b | c | a | a | b | - | a | c | a |
| Arsenous acid | - | a | a | a | - | - | a | - | b |
| Benzin | a | a | a | b | a | a | a | c | a |
| Benzoic acid | b | c | a | a | b | - | a | a | a |
| Benzene | a | c | b | b | a | c | a | c | b |
| Hydrocyanic acid | - | - | a | a | - | - | a | - | a |
| Boric acid | - | a | a | a | a | a | a | a | a |
| Butadiene | - | - | - | - | a | - | a | - | a |
| Butanoic acid | b | c | a | a | a | - | a | c | b |
| Butyl glycol | a | a | - | - | a | - | a | a | a |
| Calcium carbonate | - | - | a | a | - | a | a | - | a |
| Chlorine, wet | c | c | c | c | c | c | a | - | b |
| Chlorine, dry | c | c | b | c | b | b | a | - | a |
| Chlorobenzene | a | c | b | - | a | c | a | - | a |
| Chloroform | - | c | c | b | b | - | a | c | b |
| Chromate , 50% | - | a | b | b | c | - | a | a | b |
| Diesel fuel | a | b | a | a | a | a | a | a | a |
| Natural gas | - | - | - | - | a | a | a | - | a |

Explanation
 a = no identifiable attack (resistant)
 b = limited resistance, depending on requirement in the individual case – field test recommended
 c = heavy material attack, use not recommendable

Data refer to normal conditions!
 Under the influence of temperature, characteristics may change considerably.

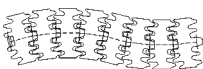

| Chemical | Active ingredient | | | | | | | | |
|---------------------------|-------------------|------------|------|---------|-----|-----|------|------|--------------------|
| | PA 6.6 30GF | PC 30GF | HDPE | PP 40Ca | POM | PVC | PVDF | RABS | Stainless steel |
| Petroleum | b | - | a | b | a | a | a | - | a |
| Acetic acid , 50% | b | a | a | a | b | a | a | a | a |
| Acetic acid , 100% | c | c | a | a | c | b | a | a | a |
| Ethyl alcohol | a | a | a | a | a | a | a | - | b |
| Fats, fatty acids | c | - | a | a | a | - | a | - | a |
| Hydrofluoric acid | a | c | - | - | - | a | a | a | b |
| Formaldehyde | - | a | a | a | a | a | a | a | b |
| Cereal oil | - | - | b | b | - | - | a | - | a |
| Transmission oil | a | a | a | b | b | a | a | - | a |
| Glucose | - | - | a | a | - | - | a | - | a |
| Heating oil | a | b | a | a | a | a | a | - | a |
| Iodine, wet | - | c | a | a | - | b | a | b | a |
| Potassium carbonate | - | b | a | a | - | a | a | - | b |
| Potassium permanganate | b | a | a | a | a | a | a | b | a |
| Potassium sulfate | - | a | a | a | - | a | a | a | a |
| Aqua regia | c | c | c | c | c | - | a | b | b |
| Carbondioxide, wet | - | a | a | a | a | a | a | - | a |
| Carbon dioxide, dry | - | a | a | a | a | a | a | - | a |
| Coco oil | - | - | a | a | b | a | a | - | a |
| Linseed oil | - | a | a | a | a | a | a | - | a |
| Methanol | b | c | a | a | a | a | a | b | a |
| Methylethyl keton | a | c | a | a | b | c | b | c | b |
| Milk | b | a | a | a | a | a | a | a | a |
| Lactic acid | b | a | a | a | a | a | a | a | b |
| Mineral oil | a | a | a | a | a | a | a | - | a |
| Sodium carbonate | a | a | a | a | b | a | a | a | b |
| Sodium cyanide | - | - | a | a | - | - | a | - | a |
| Sodium hydroxide , 50% | a | c | a | a | a | a | a | a | b |
| Nicotinic acid | - | - | a | b | - | - | a | - | a |
| Nitrobenzene | b | c | a | a | b | a/b | a | - | a |
| Oxalic acid | -- | a | a | a | - | a | a | a | a |
| Perchloric acid , 10% | - | a | a | a | b | - | a | - | c |
| Phosphoric acid , 85% | b | a | a | a | b | a | a | a | b |
| Propane | a | a | a | a | a | a | a | - | a |
| Mercury | a | a | a | a | a | a | a | a | a |
| Crude oil | - | - | a | b | a | a | a | - | a |
| Nitric acid , 65 % | c | c | b | b | c | a | a | b | b |
| Hydrochloric acid , conc. | c | c | b | b | c | a | a | a | b |
| Sulfur dioxide | a | b | a | a | c | a | a | - | a |
| Sulfuric acid , 50% | c | a | a | a | c | a | a | a | b |
| Sulfuric acid , 95% | c | c | b | b | c | a | a | b | a |
| Hydrogen sulfide | a | a | a | a | a | a | a | b | a |
| Carbon tetrachloride | a | c | c | c | b | c | a | c | a |
| Water | a | a | a | a | a | a | a | a | a |
| Hydrogen peroxide ,30% | a | a | a | a | b | a | a | b | a |
| Citric acid , 50% | a | (10%) a | a | a | b | a | a | b | a |

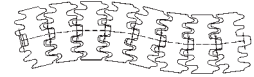

Safety instructions

General

The operator or personnel authorized by him and in charge of operating the system in accordance with their assigned tasks are solely responsible for the accident-free operation.

Occupational safety

The observance of the information on occupational safety helps to prevent any danger to persons, the environment and / or the system.

The non-observance of these information may cause the following risks under given circumstances:

- Danger to persons through mechanical, electrical, pneumatic influences
- Danger to the environment through cleaning agents and disinfectants, oils and grease
- Failure or destruction of the entire system or of individual machine parts

Before switching on the main switch, the system must be subject to an inspection.

During the start-up phase following a system restart, the system must continuously be monitored by the competent staff.

The system may only be released for regular operation after the personnel in charge have convinced themselves of the proper and safe operation and function of the entire system.

Safety and monitoring devices

In order to ensure the safety of the users in normal operation, the system is equipped with appropriate safety devices and facilities (contact protection, etc.).

Removal of safety devices

The system may never be operated without the protective and safety devices installed at the system. Before removing any safety devices (stationary and movable accident-prevention covers), the system must be shut down completely with the main switch and be protected from being switched on again unintentionally.

Maintenance

Maintenance works may only be carried out with the system stopped, i.e. with the main switch switched off (set to the O position) and secured against being switched on again using a padlock.

For all works related to operation, assembly and maintenance, the shutdown procedure and – where applicable – the required safety measures must be observed without fail.

During all production interruptions and downtimes, it must be ensured that all required safety devices are installed. Following all assembly and maintenance works it must be checked whether all safety devices are mounted and function perfectly.

Safety devices may never be bridged, bypassed or made inoperable.

Following all assembly and maintenance works, the system must be checked for left objects (tools, etc.). Such objects must be removed in order to avoid machine damage.

For the execution of certain maintenance works only professional personnel in the sense of subsection „Requirements on the personnel“ in this chapter may be employed. This particularly applies to works at pneumatic or electrical facilities.

During due function tests, the main switch may only remain switched on for the time required for the test.

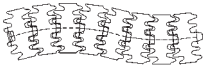

The operating staff working with and at the system must be informed about the maintenance works and may not operate the system for the period of such works.

For the maintenance and lubrication of the various assemblies and components, the related maintenance instructions and lubricant charts must be observed.

Before restarting the system, the completeness and correct execution of all maintenance works in accordance with the said regulations and information must be checked.

Emergency information

Rescue of people / First aid

In case of dangers or accidents, the system must be stopped immediately by actuating the EMERGENCY OFF pushbutton.

This can also be executed by opening a protective door or a protective window which is equipped with a safety switch and which triggers the EMERGENCY OFF function when opening it.

The EMERGENCY OFF function triggers an immediate system stop, with no consideration of the present position of the machine elements.

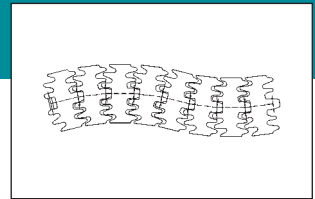

Maintenance

| Remarks b) After a malfunction has been detected (also outside the service intervals), the defect must be removed without delay. See chapter "Repair". | Maintenance intervals in 1-shift operation | | | | | Operator | Service engineer | |
|--|--|----------------------|--------------------|------------|---|----------|------------------|--|
| | 1 weekly | 2 every three months | 3 every six months | 4 annually | | | | |
| | 0 | 1 | 2 | 3 | 4 | | | |
| Check point | | | | | | | | |
| General: Before commissioning the system, make sure it is completely clean and in faultless condition. All assemblies and components must be free from foreign objects (as e.g. screws, screwdrivers, etc.). | | | | | | | | |
| Frame and link chain: | | | | | | | | |
| Check the screw connections around the cross beams at the high-grade steel frame | b) | | | • | | • | • | |
| Damaged chain links with or without tappets must be replaced without delay in order to prevent damage to frame and plastic sprocket wheels/drums | b) | | • | | | • | | |
| <u>Check longitudinal elongation:</u> If the link chain becomes visible in the lower frame area of the drive station, the chain must be shortened by approx. 1 to 2 links or more. | b) | • | | | | • | • | |
| In case of systems with horizontal and/or vertical bends, the link chain must be lubricated with silicone grease. | b) | | • | | | • | | |
| Link chains with friction rubber inserts or accumulating roller (if being used) must be checked for damage in regular intervals. Damage might affect the take-along function of the chain. | b) | • | | | | • | | |
| Drive and idler station: | | | | | | | | |
| Before starting any inspection and maintenance works at the drive station, the gear motor must be disconnected from the power supply and be protected against unintentional reactivation. | | | | | | | | |
| The ball-bearing support points of idler station, drive station and wheel bend are permanently lubricated. | b) | | | | • | | • | |
| Check tension of the roller chain at the drive station. | b) | | • | | | | • | |
| Check roller chain and sprocket wheels of gear motor and shaft of jointed band conveyor for wear. | b) | | | • | | • | | |
| Check bearings and gears / motor plate for their firm seat. | b) | | • | | | | | |
| Maintenance and service of the gear motor; proceed in accordance with the manufacturer's specifications | | | | | • | | • | |

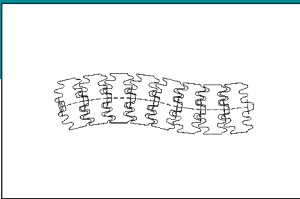

| | | | | | | | | |
|---|----|--|---|--|---|---|---|--|
| Check the gear housing, bleeding screws, and shaft seals for leakage | b) | | • | | | | • | |
| Check brake with motor decelerated and readjust, if necessary. | b) | | • | | | | • | |
| Check the power consumption of the motor. | b) | | • | | | | • | |
| Diverse: | | | | | | | | |
| Check horizontal and vertical slide bends for wear (any abnormal operation noise, irregular/rough running of the chain) lubricate with silicone spray if necessary. | b) | | • | | | • | | |
| Check sliding gibs of the standard model for wear and replace if necessary. | b) | | • | | | • | | |
| Check round belts, transition rollers and bearings of the transitions (if installed) for wear and replace if necessary. | b) | | • | | | | | |
| Check screwed connections: (if installed) - gear motor - head plate, tensioning plates, drive plates - frame, supports - switching elements - transitions - protective devices - side guides | b) | | | | • | | • | |
| Check cotter splint connections: (if installed) - shafts, axes - switching elements - lock washers | b) | | | | • | | • | |

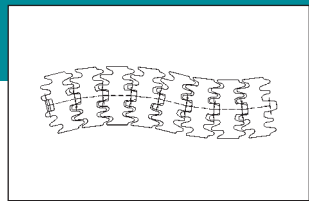

Repair

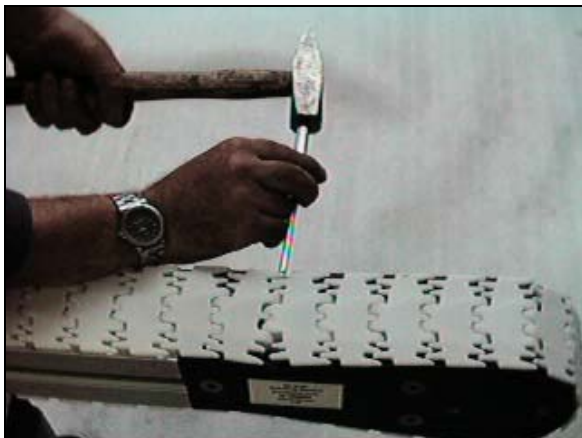

Disassembly of a chain link



Disassembly of the link chain

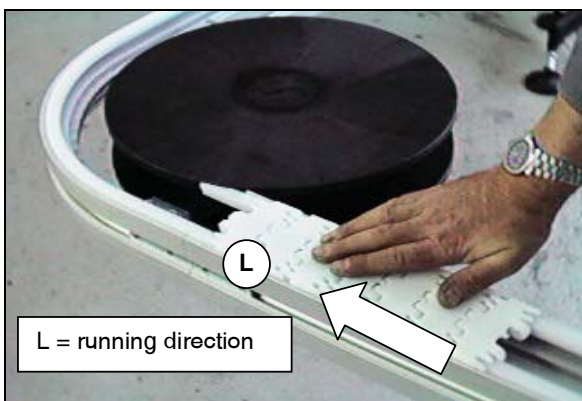

Check the running direction of the link chain

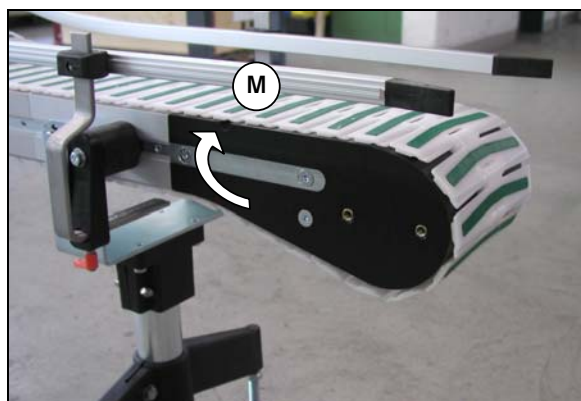

Lubrication of the link chain with silicone spray

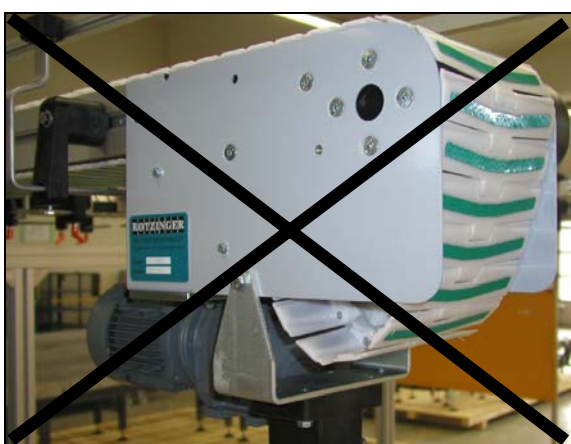

WRONG: tension of the assembled chain too low



CORRECT: chain tension correct